

Form 3029 • Price \$32.00
Edition 4 • © April 1997

CIRCLE CHART RECORDER; RECORDER CONTROLLER; RECORDER CONTROLLER
PROFILER FOR MEASURING AND CONTROLLING RELATIVE HUMIDITY

MRC 7700

Installation, Wiring, Operation Manual



Partlow
The Partlow Corporation • Two Campion Rd. • New Hartford, NY 13413 USA • 315-797-2222 • FAX 315-797-0403
QUALITY INSTRUMENTATION DESIGNED & MANUFACTURED IN THE USA

Information in this installation, wiring, and operation manual is subject to change without notice. One manual is provided with each instrument at the time of shipment. Extra copies are available at the price published on the front cover.

Copyright © April 1997, The Partlow Corporation, all rights reserved. No part of this publication may be reproduced, transmitted, transcribed or stored in a retrieval system, or translated into any language in any form by any means without the written permission of the Partlow Corporation.

This is the Fourth Edition of the MRC 7700 Recording Profile Controller Manual. It was written and produced entirely on a desk-top-publishing system. Disk versions are available by written request to the Partlow Advertising and Publications Department.

We are glad you decided to open this manual. It is written so that you can take full advantage of the features of your new MRC 7700 microbased chart recording profile controller.

NOTE

It is strongly recommended that Partlow equipped applications incorporate a high or low limit protective device which will shut down the equipment at a preset process condition in order to preclude possible damage to property or products.

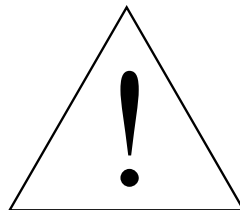

CAUTION: READ THIS MANUAL

THE INTERNATIONAL HAZARD SYMBOL IS FOUND ADJACENT TO THE PLATEN HOLD DOWN SCREW. IT IS IMPORTANT TO READ THIS MANUAL BEFORE INSTALLING OR COMMISSIONING THE UNIT.

Table of Contents

SECTION 1 - GENERAL	Page Number
1.1 Product Description	5
SECTION 2 - INSTALLATION & WIRING	
2.1 Installation & Wiring	8
2.2 Unpacking	8
2.3 Location	8
2.4 Mounting	8
2.5 Preparation for Wiring	9
2.6 Wiring Connections	14
SECTION 3 - CONFIGURATION	
3.1 Configuration (Set Up)	21
3.2 Configuration/Jumper Positioning	22
3.3 Operation Summary	22
3.4 Start Up Procedures	22
3.5 Front Panel Operation	23
SECTION 4 - OPERATION	
4.1 Operation	43
4.2 Alarm Operation	47
4.3 Tune Mode Operation	48
SECTION 5 - SERVICE	
5.1 Service	51
5.2 Changing Charts	51
5.3 Changing Pens	51
5.4 Calibration	52
5.5 Test Mode	57
5.6 Troubleshooting and Diagnostics (Error Code Definitions)	61
APPENDICES	
A - Board Layouts and Jumper Positioning	
A-1 Processor Board	69
A-2 SPST Relay/SSR Driver Output Board	70
A-3 SPDT Relay/SSR Driver Output Board	71
A-4 Current Output Board	72
B - Glossary	73
C - Order Matrix	76
D - Product Specifications	77
E - Software Reference Sheet	81
F - Profile Development Sheet	85
Warranty	Inside back cover

FIGURES & TABLES

Figure 1-1	Recorder Description	5
Figure 1-2	Recorder Display	7
Figure 2-1	Installation Panel Dimensions Conduit Opening Locations	9
Figure 2-2	Noise Suppression	11
Figure 2-3	Noise Suppression	11
Figure 2-4	Board and Terminal Locations	14
Figure 2-5	AC Power Input	15
Figure 2-6	Thermocouple Inputs	15
Figure 2-7	RTD Inputs	16
Figure 2-8	Milliamp and Volt Inputs	16
Figure 2-9	Remote Profile Run/Hold	17
Figure 2-10	Remote Setpoint Input VDC, mADC	17
Figure 2-11	Digital Communications	18
Figure 2-12	Relay Output	18
Figure 2-13	SSR Driver Output	19
Figure 2-14	Current Output	19
Figure 2-15	Transmitter Power Supply Input	20
Figure 2-16	Position Proportioning Control Output	20
Figure 3-1	Keypad Features	25
Figure 5-1	Changing Pens	50
Table 3-1	Program Mode Configuration Procedure	30
Table 3-2	Tune Mode Configuration Procedure	37
Table 3-3	Alarm Set Mode Calibration Procedure	39
Table 3-4	Profile Entry Mode Configuration Procedure	39
Table 3-5	Enable Mode Configuration Procedure	41
Table 4-1	Profile Continue Mode	44
Table 5-1	Calibration Procedures	53
Table 5-2	Test Procedures and Description	58

FLOW CHARTS

Flow - Calibration	52
Flow - Enable Mode	42
Flow - Program Mode	26
Flow - Test Mode	57
Flow - Tune Mode	36
Flow - Alarm Set	38

Product Description 1.1

1.1.1 GENERAL

The instrument is a microprocessor based circular chart Recording Profile Controller capable of measuring, displaying, recording and controlling Relative Humidity and/or Temperature using Dry Bulb and Wet Bulb temperatures from a variety of inputs. Two process sensor input terminal boards are provided on each instrument. To perform the Relative Humidity calculations both inputs must be the same type. (2- RTD, 2-J T/C, for best results a matched pair of sensors should be used). The instruments can be specified as either a single or as a dual pen model. The second pen can be selected as a profile control or a single setpoint control.

Recording, control functions, alarm settings, profile entry and other parameters are easily entered via the keypad. All user data can be protected from unauthorized changes by the Enable mode security system, and is protected against memory loss, as a result of AC power outage, by battery back-up.

The process sensor input for each terminal board is user configurable to directly connect to either thermocouple, RTD, VDC, or mADC inputs. Changes in input type can easily be made by the user. Thermocouple and RTD linearization, as well as thermocouple cold junction compensation, are performed automatically. The instrument process variable inputs are isolated. An isolated 24 VDC regulated transmitter power supply can be provided in the instrument for use with up to two 4 to 20 mADC process sensor transducers.

The instrument can be ordered to operate on either 115 VAC or 230 VAC power at 50/60 Hz. The 230 VAC option includes a switch for selecting either 230 VAC or 115 VAC operation. The Instrument is housed in a structural foam enclosure suitable for panel or surface mounting.

FIGURE 1-1

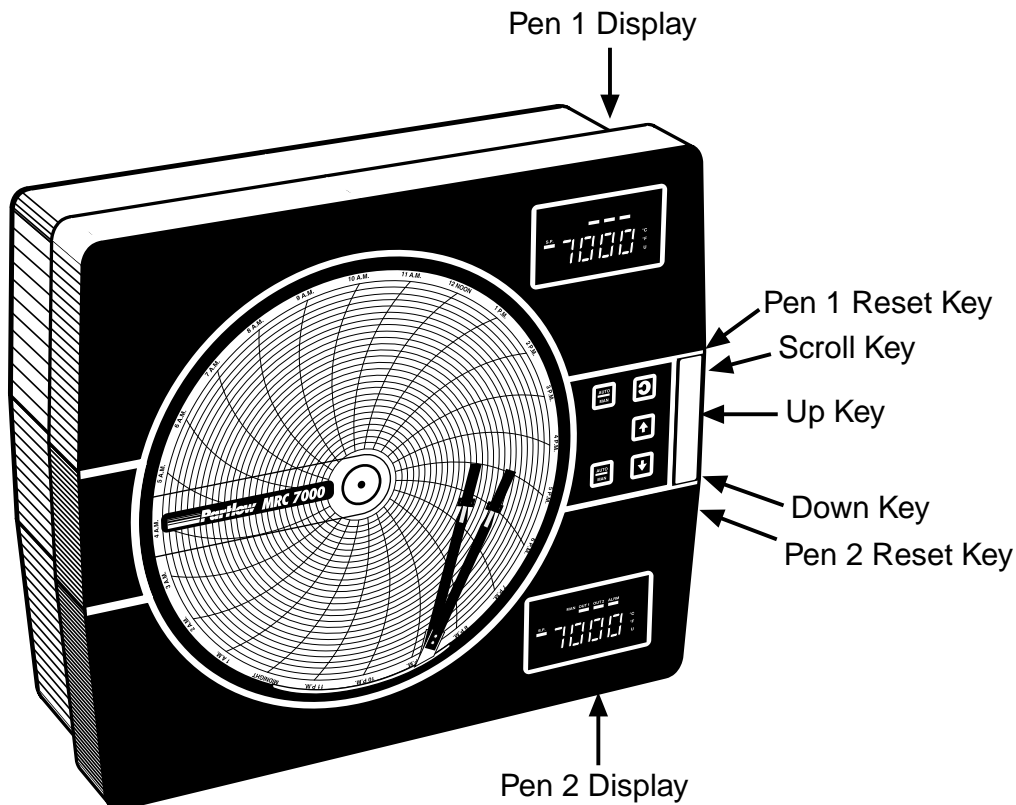

1.1.2 RECORDING

The instrument records the selected process variable on a 10-inch circular chart. One box of standard charts is provided with each recorder. Charts are available in a wide selection of ranges. Chart rotation speed is programmable from 0.1 to 999.9 hours per revolution in 0.1 hour increments. The instrument can be ordered with one or two pens. Pen 1 is red and Pen 2 is green. Pens are the disposable fiber-tip type.

1.1.3 DISPLAYS

Each instrument is provided with a digital display and status indicator for each pen provided (See Figure 1-1). The display may be configured to display the Dry Bulb Temperature, Wet Bulb Temperature, or the Relative Humidity as the process value. During configuration the display(s) is/are used to show the enabled modes of operation and the parameter codes.

The display in the upper right corner is for Pen 1, the display in the lower right corner is for Pen 2 (if provided). The upper display provides status indication for the Manual mode operation, Output 1, Output 2, Alarm, Setpoint, negative value, degrees C, degrees F, and engineering units, Ramp, Soak and six Segment lamps. The lower display (if provided) includes status indicators for Manual mode operation, Output 1, Output 2, Alarm, Setpoint, negative value, degrees C, degrees F, engineering units. (Relative Humidity will be indicated in engineering units.) See Figure 1-2 (page 7).

Display resolution is programmable for 0.1 or 1 degree for thermocouple and RTD inputs, and none, one, two or three decimal places for other input types. Relative Humidity will be indicated as whole numbers only.

1.1.4 CONTROL

The instrument can be provided with relay, solid state relay driver and milliamp DC outputs. Instruments can be programmed for on-off, time proportioning, current proportioning or position proportioning control depending upon the output(s) present. Relay(s) and Solid State Relay Driver(s) may be assigned to be on or off during the profile ramp and soak of a profile segment. Switching between the Control mode and the Manual mode of operation is easily accomplished with a dedicated key on the keypad. Switching is bumpless from the Control to the Manual mode, and while in manual, adjustment of proportional outputs is possible. Each pen of a dual pen recording controller is provided with its own AUTO/MANUAL key. Other standard control features include proportional control output limits, setpoint limits, anti-reset windup and a unique Automatic Transfer function. If configured, the Automatic Transfer function allows manual control of the proportional output until the process reaches the setpoint at which time the instrument will go into the Control mode of operation.

1.1.5 ALARM

An Alarm indicator is standard for each pen. Two alarm functions are provided for each pen and the alarm indicator will light if either alarm for that pen is on. Alarm settings are programmable. Alarm type may be selected as process direct or reverse (high or low), deviation from setpoint direct or reverse, and deviation band open or closed within the band. Alarm outputs can be provided by assigning any relay(s) Single Pole/Single Throw (SPST) or Solid State Relay (SSR) driver to the respective alarm.

1.1.6 PROCESS VALUE RE-TRANSMISSION OUTPUT

If an instrument is specified with mA/DC current output(s), any of the outputs may be programmed to operate as a process value re-transmission output. The output is scaleable but can not be used as a control output while assigned as a process value re-transmission output.

1.1.7 DIGITAL COMMUNICATIONS

The instrument can be ordered with a Digital Communications option that provides the capability of bi-directional communications with a supervisory computer. A dual pen instrument can have an individual address selected for each pen.

FIGURE 1-2

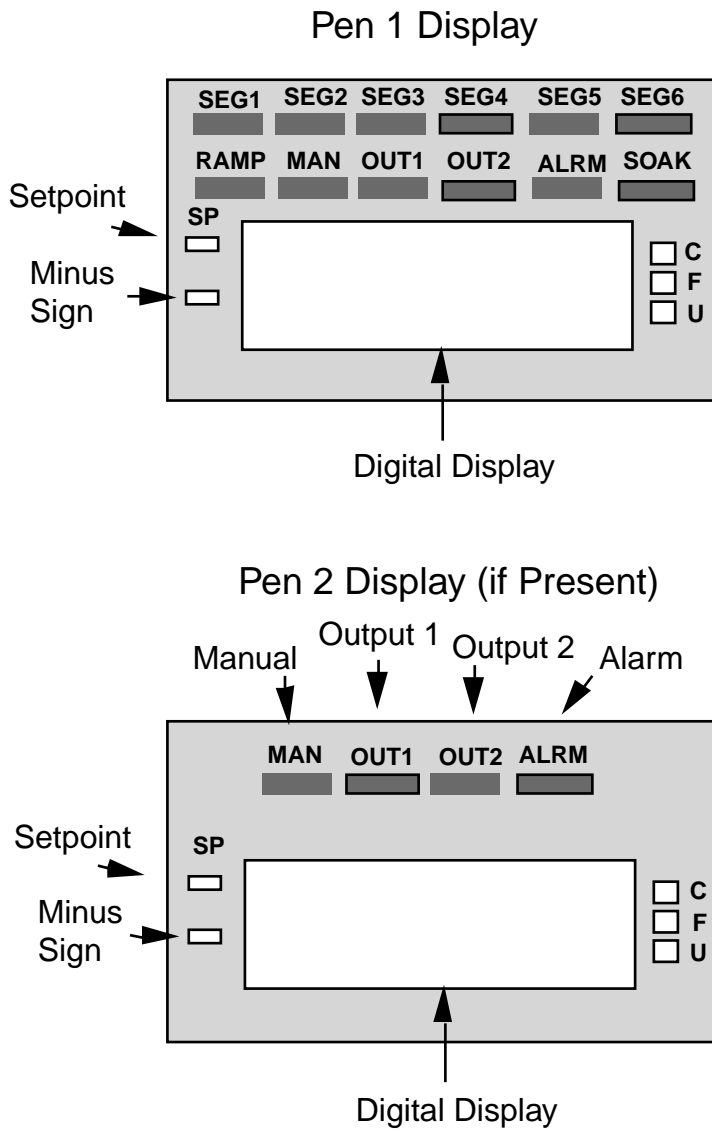

Installation and Wiring 2.1

Read these instructions carefully before proceeding with installation and operation. Electrical code requirements and safety standards should be observed. Installation should be performed by qualified personnel.

CAUTION: The Instrument AC power input is specified in the model number and on the wiring label affixed to the the top center of the platen. Verify the AC power input required by the instrument prior to proceeding with installation.

Unpacking 2.2

Remove the instrument from the carton and inspect for any damage due to shipment. If any damage is noticed due to transit, report and file a claim with the carrier. Write the model number and serial number of the instrument on the inside of the front cover of this Operation Manual for future reference.

Location 2.3

Locate the instrument away from excessive moisture, oil, dust, and vibration. Do not subject the instrument to operating temperatures outside of the 0 to 55° C (32 to 131° F) range.

Mounting 2.4

Figure 2-1 (page 9) shows an installation view and physical dimensions for a panel mounted instrument.

The panel where the instrument will be mounted must provide rigid support for the approximately 20 pound instrument. Adjacent instruments may be mounted within a minimum of 2 inches horizontally and 3 inches vertically, providing that proper panel support is supplied.

PANEL MOUNTING HARDWARE REQUIRED: (not provided with instrument)

- (4) 1/4"-20 x 2" flat head bolts w/nuts
- (4) appropriate lock washers

PANEL MOUNTING:

- 1) Cut panel opening to the dimensions illustrated in Figure 2-1 (page 9).
- 2) Insert the instrument in the panel opening. Firmly fasten the instrument to the panel using the nuts, bolts and lock washers.

SURFACE MOUNTING:

- 1) Install the mounting brackets, ordered separately, on the vertical sides of instrument housing. Use the brackets to fasten the instrument to the surface.

FIGURE 2-1

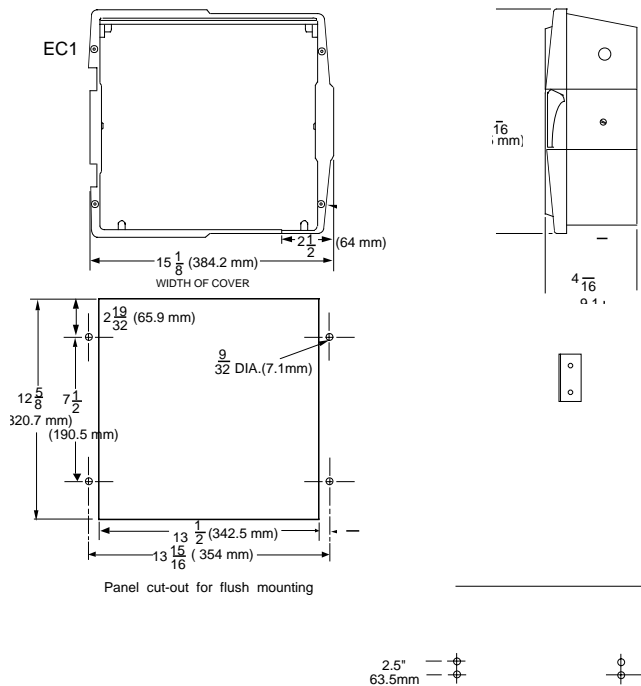

Preparations for Wiring 2.5

2.5.1 WIRING GUIDELINES

Electrical noise is a phenomenon typical of industrial environments. The following are guidelines that must be followed to minimize the effect of noise upon any instrumentation.

2.5.1.1 INSTALLATION CONSIDERATIONS

Listed below are some of the common sources of electrical noise in the industrial environment:

- Ignition Transformers
- Arc Welders
- Mechanical contact relay(s)
- Solenoids

Before using any instrument near the devices listed, the instructions below should be followed:

1. If the instrument is to be mounted in the same panel as any of the listed devices, separate them by the largest distance possible. For maximum electrical noise reduction, the noise generating devices should be mounted in a separate enclosure.
2. If possible, eliminate mechanical contact relay(s) and replace with solid state relays. If a mechanical relay being powered by an instrument output device cannot be replaced, a solid state relay can be interposed to isolate the instrument.
3. A separate isolation transformer to feed only instrumentation should be considered. The transformer can isolate the instrument from noise found on the AC power input.
4. If the instrument is being installed on existing equipment, the wiring in the area should be checked to insure that good wiring practices have been followed.

2.5.1.2 AC POWER WIRING

Earth Ground

The instrument includes noise suppression components that require an earth ground connection to function. To verify that a good earth ground being is attached, make a resistance check from the instrument chassis to the nearest metal water pipe or proven earth ground. This reading should not exceed 100 ohms.

Neutral (For 115VAC)

It is good practice to assure that the AC neutral is at or near ground potential. To verify this, a voltmeter check between neutral and ground should be done. On the AC range, the reading should not be more than 50 millivolts. If it is greater than this amount, the secondary of this AC transformer supplying the instrument should be checked by an electrician. A proper neutral will help ensure maximum performance from the instrument.

2.5.1.3 WIRE ISOLATION/SEGRATION

The instrument is designed to promote proper separation of the wiring groups that connect to the instrument. The AC power wire terminals are located near the top of the instrument boards. The analog signal terminals are located near the bottom of the instrument boards. Maintain this separation of the wires to insure the best protection from electrical noise. If the wires need to be run parallel with any other wiring type(s), maintain a minimum 6 inch space between the wires. If wires must cross each other, do so at 90 degrees to minimize the contact with each other and reduces cross talk. Cross talk is due to the EMF (Electro Magnetic Flux) emitted by a wire as current passes through it.

2.5.1.4 USE OF SHIELDED CABLE

Shielded cable helps eliminate electrical noise being induced on the wires. All analog signals should be run with shielded cable. Connection lead length should be kept as short as possible, keeping the wires protected by the shielding. The shield should be grounded at one end only. The preferred grounding location is at the sensor, transmitter or transducer.

2.5.1.5 NOISE SUPPRESSION AT THE SOURCE

Usually, when good wiring practices are followed, no further noise protection is necessary. Sometimes in severe electrical environments, the amount of noise is so great that it has to be suppressed at the source. Many manufacturers of relays, contactors, etc., supply "surge suppressors" which mount on the noise source.

For those devices that do not have surge suppressors supplied, RC (resistance-capacitance) networks and/or MOV (metal oxide varistors) may be added.

Inductive Coils - MOV's are recommended for transient suppression in inductive coils connected in parallel and as close as possible to the coil. See Figure 2-2. Additional protection may be provided by adding an RC network across the MOV.

Contacts - Arcing may occur across contacts when the contact opens and closes. This results in electrical noise as well as damage to the contacts. Connecting a RC network properly sized can eliminate this arc.

For circuits up to 3 amps, a combination of a 47 ohms resistor and 0.1 microfarad capacitor (1000 volts) is recommended. For circuits from 3 to 5 amps, connect 2 of these in parallel. See Figure 2-3.

FIGURE 2-2

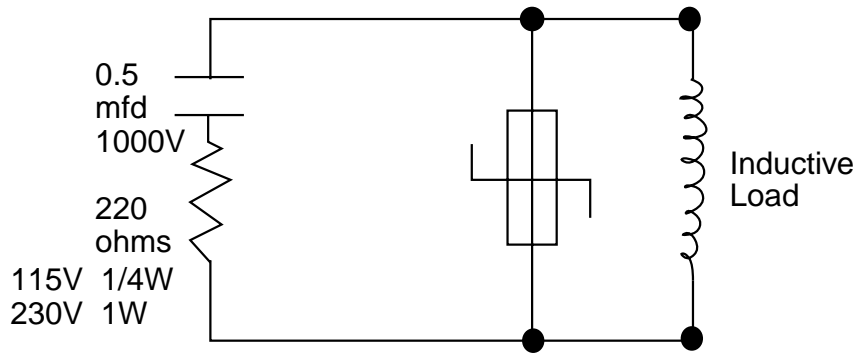
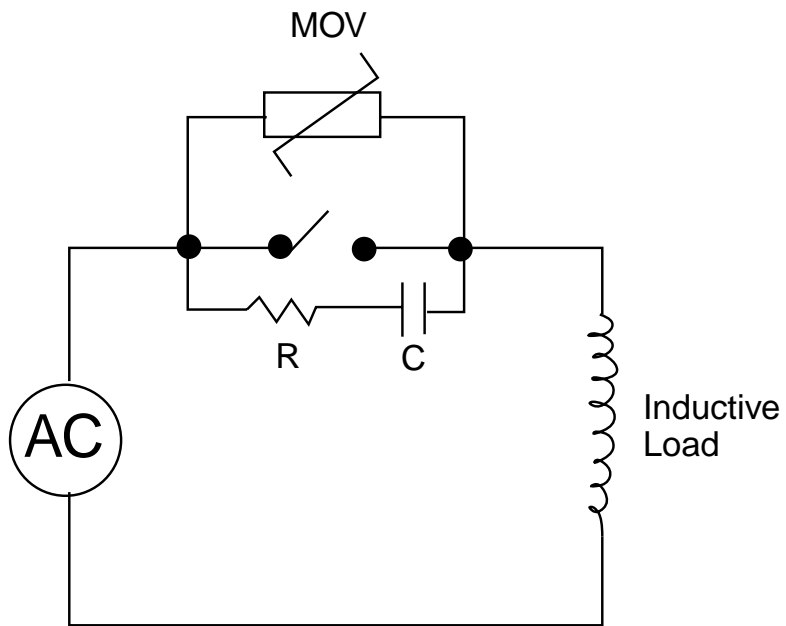

FIGURE 2-3



2.5.2 SENSOR PLACEMENT (Thermocouple or RTD)

If the temperature probe is to be subjected to corrosive or abrasive conditions, it should be protected by the appropriate thermowell. The probe should be positioned to reflect true process temperature:

- In liquid media - the most agitated area.
- In air - the best circulated area.

THERMOCUPLE LEAD RESISTANCE

Thermocouple lead length can affect instrument accuracy since the size (gauge) and the length of the wire affect lead resistance.

To determine the temperature error resulting from the lead length resistance, use the following equation:

$$T_{err} = TLe * L \quad \text{where; } TLe = \text{value from appropriate Table}$$

$$L = \text{length of leadwire in thousands of feet}$$

TABLE 1

Temperature Error in °C per 1000 feet of leadwire									
AWG No.	Thermocouple Type								
	J	K	T	R	S	E	B	N	C
10	0.68	1.71	0.76	2.05	2.12	1.15	14.00	2.94	2.53
12	1.08	2.68	1.21	3.30	3.29	1.82	22.00	4.68	4.07
14	1.74	4.29	1.95	5.34	5.29	2.92	35.00	7.44	6.37
16	2.74	6.76	3.08	8.30	8.35	4.60	55.50	11.82	10.11
18	4.44	11.00	5.00	13.52	13.65	7.47	88.50	18.80	16.26
20	7.14	17.24	7.84	21.59	21.76	11.78	141.00	29.88	25.82
24	17.56	43.82	19.82	54.32	54.59	29.67	356.50	75.59	65.27

TABLE 2

Temperature Error in °F per 1000 feet of leadwire									
AWG No.	Thermocouple Type								
	J	K	T	R	S	E	B	N	C
10	1.22	3.07	1.37	3.68	3.81	2.07	25.20	5.30	4.55
12	1.94	4.82	2.18	5.93	5.93	3.27	39.60	8.42	7.32
14	3.13	7.73	3.51	9.61	9.53	5.25	63.00	13.38	11.47
16	4.93	12.18	5.54	14.93	15.04	8.28	99.90	21.28	18.20
18	7.99	19.80	9.00	24.34	24.56	13.44	159.30	33.85	29.27
20	12.85	31.02	14.12	38.86	39.18	21.21	253.80	53.79	46.68
24	31.61	78.88	35.67	97.77	98.26	53.40	641.70	136.07	117.49

Example

A recorder is to be located in a control room 660 feet away from the process. Usinging 16 AWG, type J themrocouple, how much error is induced?

$$T_{err} = TLe * L$$

$$TLe = 4.93 \text{ (°F/1000 ft) from Table 2}$$

$$T_{err} = 4.93 \text{ (°F/1000 ft)} * 660 \text{ ft}$$

$$T_{err} = 3.3\text{°F}$$

RTD LEAD RESISTANCE

RTD lead length can affect instrument accuracy. Size (gauge) and length of the wire used affects lead length resistance.

To determine the temperature error resulting from the lead length resistance, use the following equation:

$$T_{err} = TLe * L \quad \text{where; } TLe = \text{value from Table 3 if 3-wire or Table 4 if 2-wire}$$

$$L = \text{length of leadwire in thousands of feet}$$

TABLE 3 3 Wire RTD

AWG No.	Error °C	Error °F
10	+/-0.04	+/-0.07
12	+/-0.07	+/-0.11
14	+/-0.10	+/-0.18
16	+/-0.16	+/-0.29
18	+/-0.26	+/-0.46
20	+/-0.41	+/-0.73
24	+/-0.65	+/-1.17

TABLE 4 2 Wire RTD

AWG No.	Error °C	Error °F
10	+/-5.32	+/-9.31
12	+/-9.31	+/-14.6
14	+/-13.3	+/-23.9
16	+/-21.3	+/-38.6
18	+/-34.6	+/-61.2
20	+/-54.5	+/-97.1
24	+/-86.5	+/-155.6

Example

An application uses 2000 feet of 18 AWG copper lead wire for a 3-wire RTD sensor. What is the worst case error due to this leadwire length?

$$T_{err} = TLe * L$$

$$TLe = +/- .46 (°F/1000 ft) \text{ from Table 1}$$

$$T_{err} = +/- .46 (°f/1000 ft) * 2000 \text{ feet}$$

$$T_{err} = +/- 0.92 °F$$

Wiring Connections 2.6

All wiring connections are typically made to the instrument at the time of installation. Connections are made at the terminal boards provided, two 12 gauge wires maximum, using copper conductors only, except thermocouple inputs. Terminal blocks are designated TB1 through TB13. See Figure 2-2 for the terminal block locations. The number of terminal blocks present on the instrument depend upon the model number/hardware configuration.

FIGURE 2-4

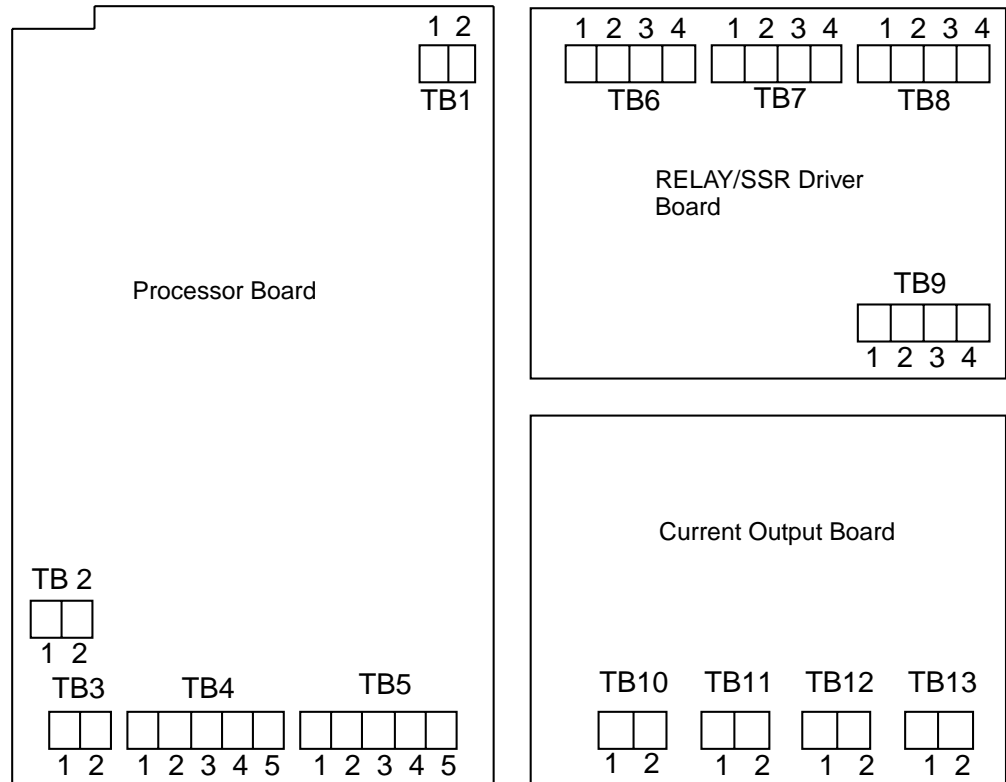

2.6.1 ELECTRICAL CONDUIT OPENINGS

The instrument case will have 3 or 4 conduit openings, depending upon the number of outputs specified. To help minimize electrical noise that may adversely affect the operation of the instrument, the wires groups indicated below should be routed through the conduit opening specified. See Figure 2-1 for conduit opening locations.

- EC1- AC Power Input
- EC2- Analog input and mADC outputs
- EC3- SPST or SPDT relay or SSR driver outputs
- EC4- SPST or SPDT relay or SSR driver outputs (provided when > 4 relays & SSR Drivers total are specified)

Unused conduit openings should be sealed.

2.6.2 AC POWER WIRING CONNECTIONS

WARNING: Avoid electrical shock. AC power wiring must not be connected at the source distribution panel until all wiring connections are completed.

FIGURE 2-5

AC Instrument Power Input

Connect the 115 VAC hot and neutral to terminals 1 and 2 respectively of TB1. See Figure 2-4 (page 14) for Terminal Block locations on the instrument. Connect the 230 VAC one leg to each terminal, be sure to check the position of the Voltage Selector switch provided with 230 VAC instruments. The switch position must match the voltage input to the instrument.

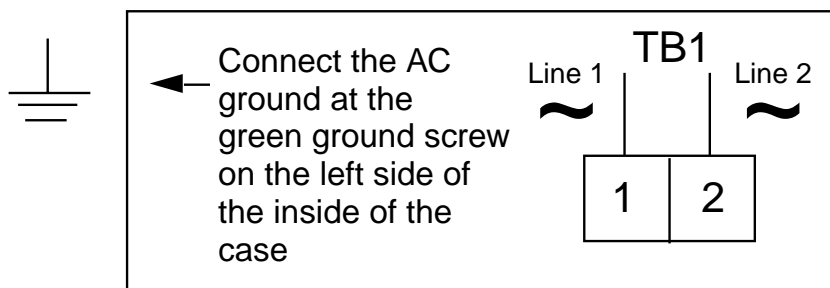

FIGURE 2-6

Thermocouple Inputs

For Relative Humidity calculations both sensor inputs must be the same kind. For best results, a matched pair of sensors should be used. Use TB4 for the Dry Bulb input, and TB5 for the Wet Bulb input. Connect the positive leg of the thermocouple to terminal 1, and the negative to terminal 2. Be sure that the input conditioning jumpers are properly positioned for a thermocouple input. See Appendix A-1 (page 68).

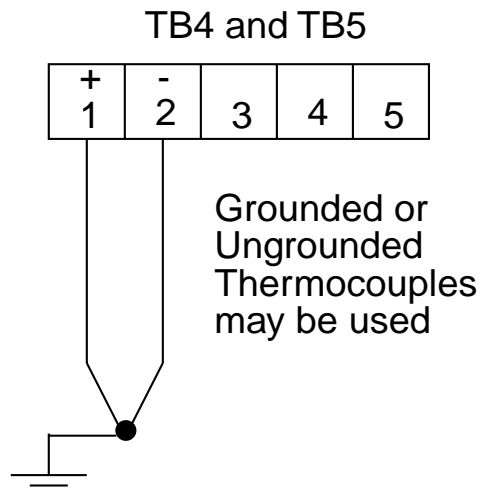

FIGURE 2-7

RTD Inputs

For Relative Humidity calculations both sensor inputs must be the same kind. For best results, a matched pair of sensors should be used. Use TB4 for the Dry Bulb input, and TB5 for the Wet Bulb input. Connections are shown for 3 wire and 2 wire RTD inputs. If a three wire device is used, install the common legs to terminals 2 and 3. If a two wire device is used, install a jumper between terminals 2 and 3. Be sure that the input conditioning jumpers are properly positioned for an RTD input. See Appendix A-1 (page 68).

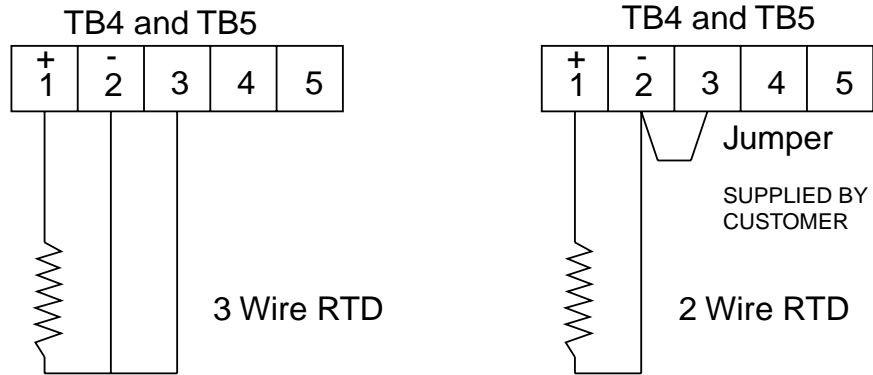

FIGURE 2-8

Volt and milliamp Input

Make the volt and milliamp connections as shown below. Use TB4 for the Dry Bulb input, and TB5 for the Wet Bulb input. Terminal 1 is positive and terminal 2 is negative. The milliamp input requires the installation of an appropriate shunt resistor (ordered separately) between terminals 1 and 2. Be sure that input conditioning jumpers are in the correct positions for the input being connected. See Appendix A-1 (Page 68).

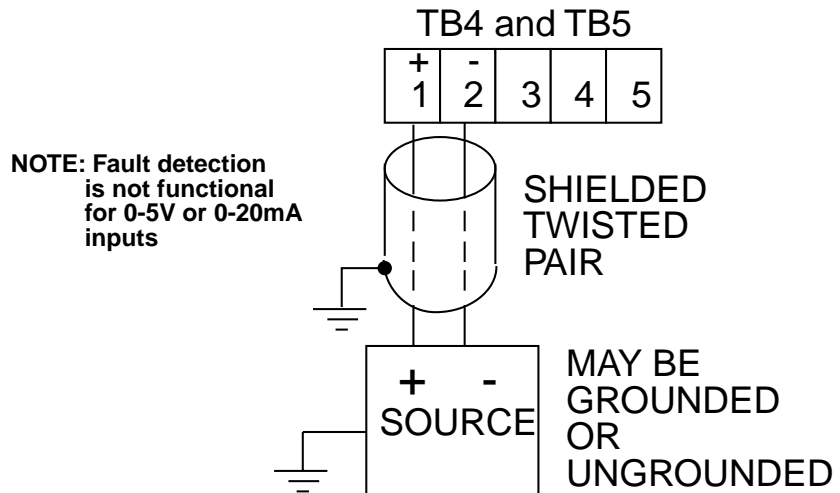

FIGURE 2-9

Remote Profile Run/Hold

If the Remote Run/Hold option has been specified, make the connections as shown. The Remote Run/Hold option provides the capability of halting and restarting a running profile from the operation of a remote contact closure. The operation of the Remote Run/Hold is determined by the Program mode parameter selected. The closure of a remote dry contact will cause the profile to hold. Re-opening the contact will cause the profile to continue to run from the point at which it was halted. If both pens on a dual pen instrument are selected to profile control the Remote Run/Hold will affect the operation of both pens.

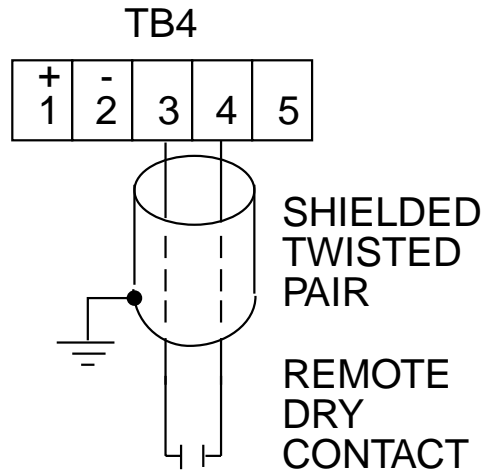

FIGURE 2-10

Remote Setpoint Input VDC, mADC (Optional for the second pen of dual pen instruments)
 If Remote Setpoint option has been specified, make connections as shown. The remote setpoint input may be selected as either 0 to 5 VDC or 1 to 5 VDC input in the Program mode section. Make sure the configuration properly matches the input used. Connect the positive lead to terminal 4, and the negative lead to terminal 3 (Terminal 3 is the ground, terminal 4 is the input, terminal 5 is 5 VDC.) If a 4 to 20 mADC remote setpoint is to be used, the instrument remote setpoint input should be configured for 1 to 5VDC in the Program mode, and a 250 ohm resistor should be installed across terminals 4 and 3.

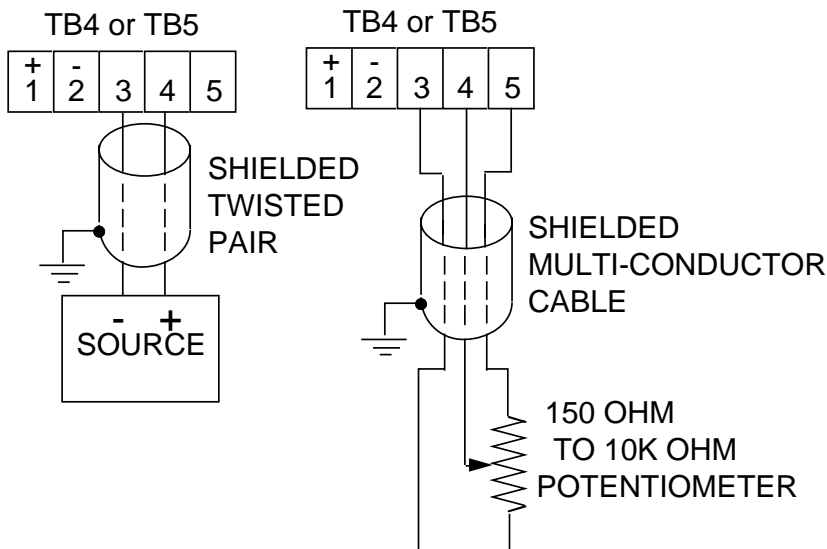
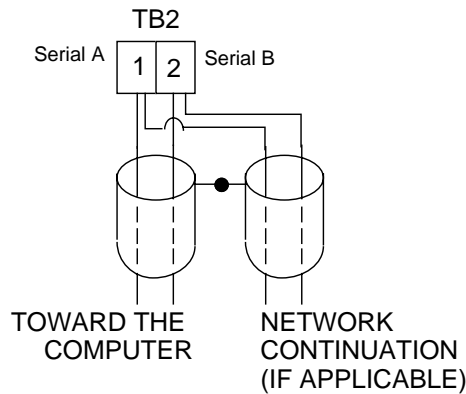

FIGURE 2-11

Digital Communications Options

Connections are made as shown using TB2. Refer to the Protocol Manual, Form #2878 for more details regarding the connections and how to use this option. This document is provided only when this option has been specified. If the communications network continues on to other instruments, connect the cable shields together, but not to the instrument. A terminating resistor should be installed at the terminals of the last unit in the communications loop. If the communications network ends at the instrument, the shield is not connected.



2.6.4 OUTPUT CONNECTIONS

Relay output(s), if provided in the instrument, may be assigned to control or alarm output functions for Pen 1 and/or Pen 2 (if present). Current outputs may be assigned to control and process value retransmission output for Pen 1 and/or Pen 2 (if present). The assignment of the output function (s) are/is accomplished in the Program mode. SPST relay and/or SSR driver output(s) is/are designated as Relay A through Relay H. SPST relays begin with Relay A designation, then B, C, etc. SSR drivers begin with Relay H designation then G, F, etc. except when 4 SSR drivers are required in conjunction with SPDT relays, then designation E & F are not available. SSR driver designation becomes G, H, D, and C. SPDT relay output(s) are designated as Relay A and Relay B only.

FIGURE 2-12A

SPST Relay Output

Connections are made to relays A through F as shown. Terminal connections are made using TB6 (Relay/SSR Driver A, B), TB7 (Relay/SSR Driver C, D) and TB8 (Relay/SSR Driver E, F).

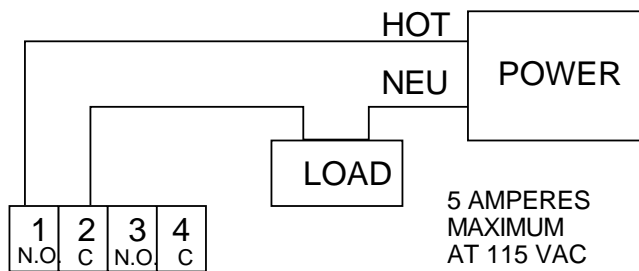

TB6 Relay A & B, Relay A Terminals 1 & 2
 TB7 Relay C & D, Relay C Terminals 1 & 2
 TB8 Relay E & F, Relay D Terminals 1 & 2

FIGURE 2-12B
SPDT Relay Output

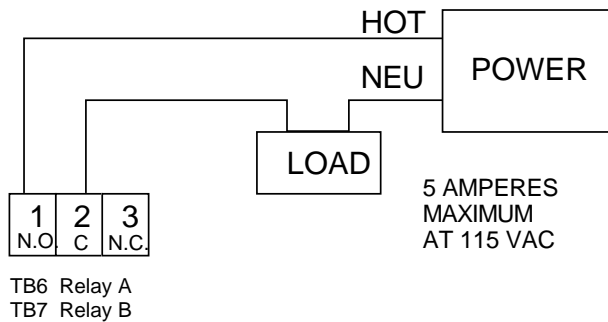
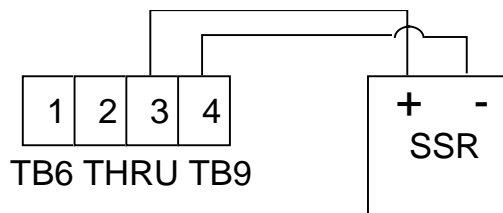

FIGURE 2-13
SSR Driver Output
Connections are made to relays H through A as shown. Terminal connections are made using TB9, TB8, etc. depending on the number of SSR Driver outputs specified.



TB9 SSRD G, H - all cases
TB8 SSRD E, F - no SPDT relays
TB8 SSRD C,D - SPDT relay/s E and F not available

FIGURE 2-14
Current Output
Connections are made to current outputs A through D as shown. Each current output is programmable as either 4 to 20 mADC or 0 to 20 mADC. Each output must be assigned to the desired function in the Program mode. Terminal connections are made using TB10 through TB13 for current output A through D respectively. Connect positive lead (+) to terminal 1 and the negative lead (-) to terminal 2. Each current output will operate up to a 650 ohms maximum load.

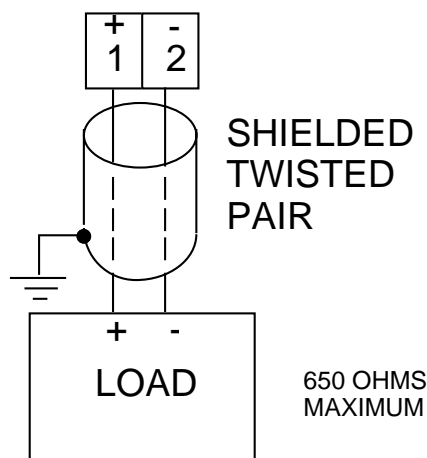

FIGURE 2-15

Transmitter Power Supply Input

If the isolated 24 VDC regulated transmitter power supply has been specified, the connections should be made as shown. Connections are made using TB3, terminal 1 is positive and terminal 2 is negative. The power supply is capable of providing the power needed for up to 2 transducers.

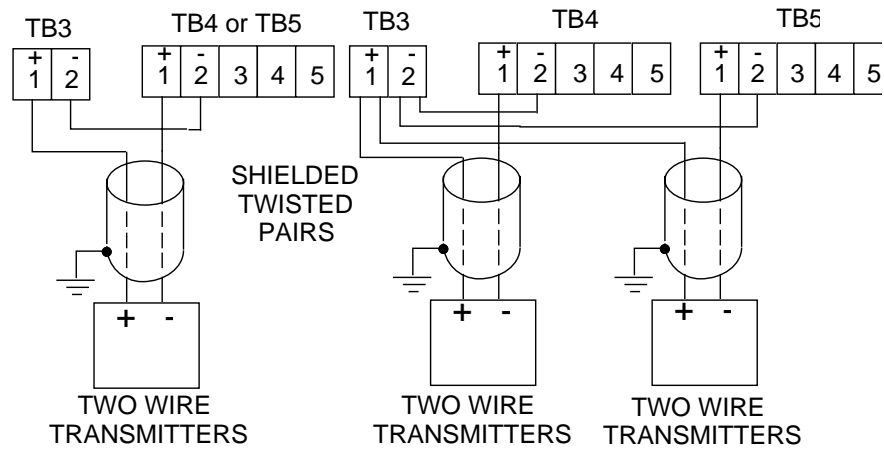
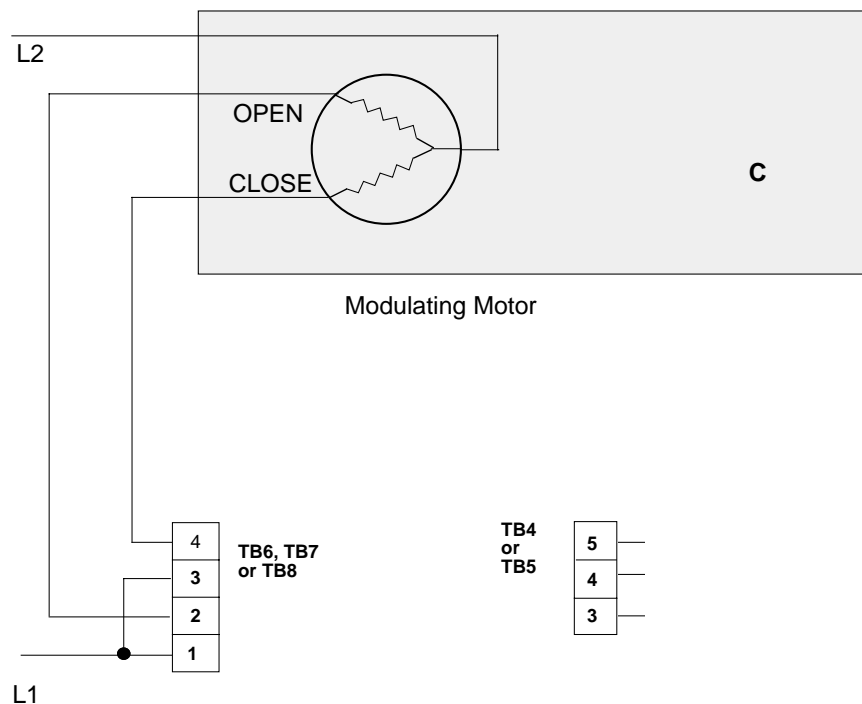

FIGURE 2-16

Position Proportioning Control Output

Position Proportioning control requires that two relays (or SSR Drivers) and the Position Proportioning Auxiliary input be specified. On a dual pen instrument either pen may be configured with Position Proportioning control provided the outputs and auxiliary inputs have been properly specified.



Configuration 3.1

After completing installation and wiring of the instrument the configuration (set up) procedures must be performed to prepare the instrument for operation on the intended application. The procedures include selecting specific parameters, entering data and possible jumper positioning. Once properly configured the instrument will retain the user selections in memory so this procedure need not be repeated unless required by changes in the application.

Parameter selections and data entry are made via the front keypad. To ease configuration and operation, user entered data has been divided up into several sections referred to as modes. Each mode contains a different type of data or may be used for specific operating functions. For two pen instruments, some modes are common to both pens. These modes are as follows:

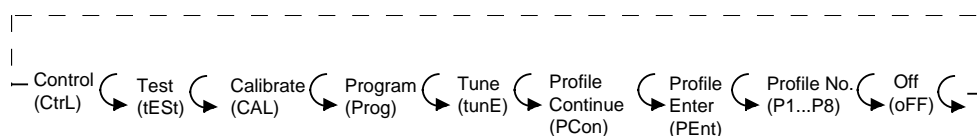

Mode	Display Code	Function	Description
Off	oFF	Operation	Outputs and Alarms are Off. Chart may stop rotating (selectable)
Control (Operate)	Ctrl (oPEr)	Control (Operation)	Outputs and Alarms are Active (<i>Recorder</i>)
Test	tESt	Service	Tests Instrument Operation
Calibration	CAL	Service	Calibrates, Resets Instrument
Program	Prog	Configuration	Configure Operating Parameters
Tune (Alarm Set)	tunE (ASEt)	Configuration & Operation	Enter Tune and Alarm Settings Operation (<i>Recorder</i>)
Profile Entry	PEnt	Configuration	Enter the Profile program(s)
Profile Continue	PCon	Operation	Provides the means to restart a profile anywhere within the program
Setpoint Change	ESPC	Operation	Prohibits setpoint change from the keypad
Enable	Enab	Configuration	Mode security system, can lock out everything except off and operate (See Appendix A-1, page 68, for hardware lockout information)

Associated with each mode is a series of unique displays that are accessed via the front keypad.

Prior to first time operation of the instrument, the configuration procedures for the Program and Tune modes must be performed as applicable. Calibration and Test modes are not used as part of the instrument configuration or operation. These are used for service and maintenance functions and are discussed in Section 5.6 (page 59) of this manual.

Shipped Configuration/ Jumper Positioning 3.2

Each instrument is factory shipped ready to accept a RTD input on TB 4 and TB 5. All parameters in each mode are set to default values. These defaults are shown in tabular form after the description for each mode. Instrument AC power input is as specified in the instrument model number and is shown on the ratings label. The 230 VAC option includes a switch in the instrument for selecting either 230 VAC or 115 VAC input power. If this feature is provided, verify AC input and switch position before applying power to the instrument.

3.2.1 JUMPER POSITIONING

Jumpers are used to condition the sensor inputs and to provide a security lockout feature. All jumpers are located on the instrument Processor board. The instrument board layout and jumper locations and functions are shown in Appendix A-1 (Page 68). Check the jumper positions in the instrument and verify that they are in the proper position for the intended application.

The sensor input jumpers JU4, JU5, JU6 and JU7 condition the sensor input signals and must be used in conjunction with input type selections made in the Program mode (page 30).

Operation Summary 3.3

3.3.1 MODE SELECTION

If the instrument is either in the Off mode or the Control mode repeated pressing and releasing of the SCROLL key will cause the instrument to display the code corresponding to each mode that is enabled. To enter a mode, while the code is displayed, press the DOWN key. If a mode does not appear, refer to the Enable mode section for information on how to determine that the mode is on.

Entry into any mode except the Control, Tune, Manual and Enable modes, will cause the output(s) to turn off and any process re-transmission value output(s) to be 0 %.

Entry into Off mode will cause the process re-transmission output to remain active.

Start Up Procedures 3.4

All configuration parameters are listed in Tables 3-1 through 3-5.

For a single pen instrument, parameters for each mode are displayed in the upper right display. If the instrument being configured is a two pen model, a sequence of applicable parameters will be displayed in the Pen 2 display after the Pen 1 parameters have been reviewed and configured. After the Pen 2 parameters have been completed, parameters common to both pens will be configured and displayed in the Pen 1 display.

The instrument is provided with a time out feature. If the instrument is in any mode and no keypad activity takes place for 30 seconds, the instrument will time out and exit the mode automatically. The display will become the code for the respective mode. If a mode code is displayed for 5 seconds with no keypad activity, then the time out will cause the instrument to proceed to either the Control or Off mode, depending upon which operational state was in use before entry into the mode.

3.4.1 POWER UP PROCEDURE

A. Verify that all electrical connections have been properly made before applying power to the instrument.

B. For instruments with software revision R2.99 and below

Upon power up, **77XX** will be displayed (X representing digits), then **XXXX**, then **XXXX**, identifying the twelve digit model number as defined in the order matrix. Next, the EPROM part number will be indicated **P-XX**. After the EPROM part number, the software revision level will be displayed in the format **rX.XX** then **tSt1**, **tSt2**, and **tSt3** will be displayed while Test 1 through 3 are executed automatically. Upon successful completion of these test, **oPEr** or **oFF** will be displayed for about 3 seconds. The mode displayed will be the mode the instrument was in when the power was turned off. During this time, the operator may select another mode (Alarm Set, Enable) or non-operational mode (Test, Program, Cal).

C For instruments with software revision r3.00 and above

Upon power up, a brief flash on all displays (upper and, if equipped, lower) will occur to show the instrument is "alive". Then **77XX** will be displayed (X representing digits) then **XXXX**, then **XXXX**, identifying the twelve digit model number as defined in the order matrix. Next, the EPROM part number will be indicated **P-XX**. After the EPROM part number, the software revision level will be displayed in the format **rX.XX** followed by **P.dn** (if Pen Action on Power Up, **PAPU**, in Program Mode is set to **0**, pens go to "home" position at power up). During this display, the decimal point after the "P" will blink to show the mode is active. Upon successful completion of this routine, **oPEr** or **oFF** will be displayed for about 3 seconds. The mode displayed will be mode that the instrument was in when the power was turned off. During this time the operator may select another mode (Alarm Set, Enable) or non-operational mode (Test, Program, Cal).

D. If any error messages are displayed, refer to Section 5.6 (page 60) for a definition of the error message and the required action.

Front Panel Operation 3.5

3.5.1 DIGITAL DISPLAY AND STATUS LED's

The digital display provided for each pen has 4 digits and a decimal point. Each digit has seven segments and is capable of producing numeric characters from 0-9 and certain alpha characters. The digital display is used to provide indication of process variable as well as displaying codes used for configuration and operation of the instrument. The display includes the following Status Indicator LED's;

<u>Label</u>	<u>Color</u>	<u>Function</u>
MAN	Amber	Lights when the Manual (StbY) mode is on.
OUT1	Red	Lights when Output 1 is on or mADC output selected. (ALRM 1 Recorder)
OUT 2	Amber	Lights when Output 2 is on or mADC output selected. (ALRM 2 Recorder)
ALRM	Red	Lights when either Alarm is on.
C	Red	Lights to indicate that the process value is in degrees C (Celsius).

F	Red	Lights to indicate that the process value is in degrees F (Fahrenheit).
U	Red	Lights to indicate that the process value is in terms of Relative Humidity or Engineering units.
SP	Green	Indicates that the value displayed is the setpoint.
-	Red	Lights to indicate a negative displayed value.
RAMP	Red	Lights to indicate that a profile is running and is ramping the setpoint.
SOAK	Red	Lights to indicate that a profile is running and is at a constant setpoint.
SEG1-6	Red	Lights to indicate that a profile is running and is in the segment that is lit.

*Refer to Figure 1-2 (page 7) for the display features illustration.

3.5.2 KEYPAD CONTROLS

The keys on the keypad functions include:

SCROLL: Used to :

1. Display the enabled modes.
2. While in a mode, used to sequence the parameter codes and values.
3. Exit some Test and Calibration functions
4. Work in conjunction with other keys:
 - a. With the UP key to display proportional output %
 - b. With the DOWN Key;
 - 1) On power up to alter model #
 - 2) Enter Cal/Test functions

UP: Used to:

1. Exit a mode.
2. Turn a mode On in the Enable mode
3. Increase a parameter numerical value
4. View the setpoint for Pen 1 (Press and release)
5. Increase the setpoint value (Press and hold)
6. Work in conjunction with other keys:
 - a. With the SCROLL key to display proportional output %
 - b. With the DOWN key;
 - 1) On power up to reset the instrument
 - 2) Lamp test (Press and release)
 - 3) Enter the Enable mode (Press and hold)

DOWN: Used to:

1. Enter a mode
2. Turn a mode Off in the Enable mode
3. Decrease a parameter numerical value
4. View the setpoint for Pen 2 (if provided)
5. Decrease the setpoint value (Press and hold)
6. Step display through parameter codes in a mode
7. Start a profile
8. Work in conjunction with other keys:
 - a. With the SCROLL key;
 - 1) On power up to alter the model number displayed
 - 2) Enter Cal/Test functions
 - b. With the UP key;
 - 1) On power up resets the instrument
 - 2) Lamp test (Press and release)
 - 3) Enter the Enable mode (Press and hold)

AUTO/MAN: Used to:
 The upper key is for Pen 1, the lower key is for Pen 2 (if provided)

1. In the Control mode to enter the Manual mode if proportional output(s) selected
2. In the Manual mode to enter the Control mode if proportional output(s) selected

RUN/HOLD: Used to:

1. To start a profile.
2. To halt a running profile

FIGURE 3-1

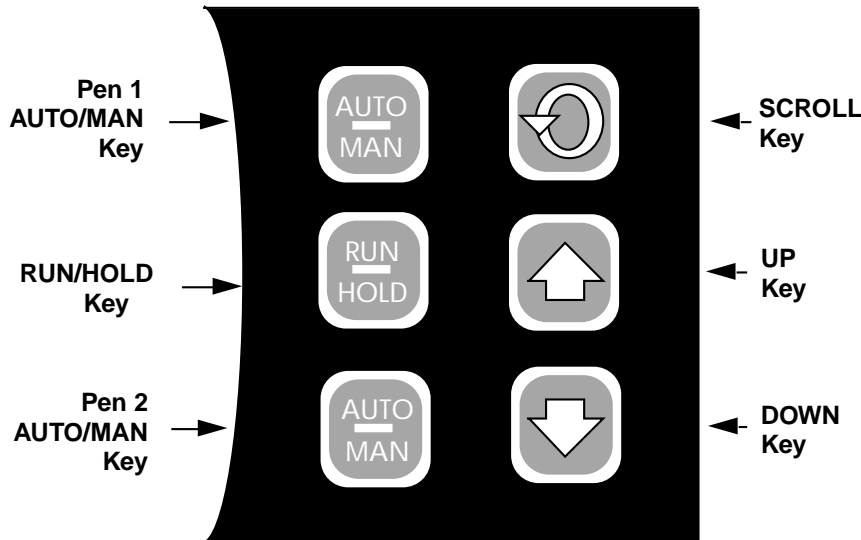

Lamp Test

All display and status LED's can be illuminated simultaneously by depressing the UP and DOWN keys at the same time. Any defective LED's will not light.

***CHANGE CHART (also see Changing Charts, Section 4.2)**

If the UP and DOWN keys are held depressed for more than 2 seconds but less than 4 seconds, the display will show **Cchg** momentarily. The pen(s) will move to and remain at a point above the top graduation on the chart and the chart will stop rotation to allow the chart to be changed. The pens will remain fully upscale with the chart OFF; otherwise, the unit will continue to operate normally in the current mode. To restore pen(s) position and chart rotation, press the UP and DOWN keys for more than 2 seconds but less than 4 seconds.

***PEN RESYNCHRONIZATION**

To resynchronize the pen(s), depress the UP and DOWN keys for 4 seconds, the display will show **P dn** momentarily, the pen(s) are driven to the "Pen Home" position below the bottom graduation on the chart while the unit resynchronizes their position. After about 14 seconds, the pen(s) will return to their correct position. All other functions of the unit's present mode continue to operate normally.

PROGRAM MODE FLOW CHART

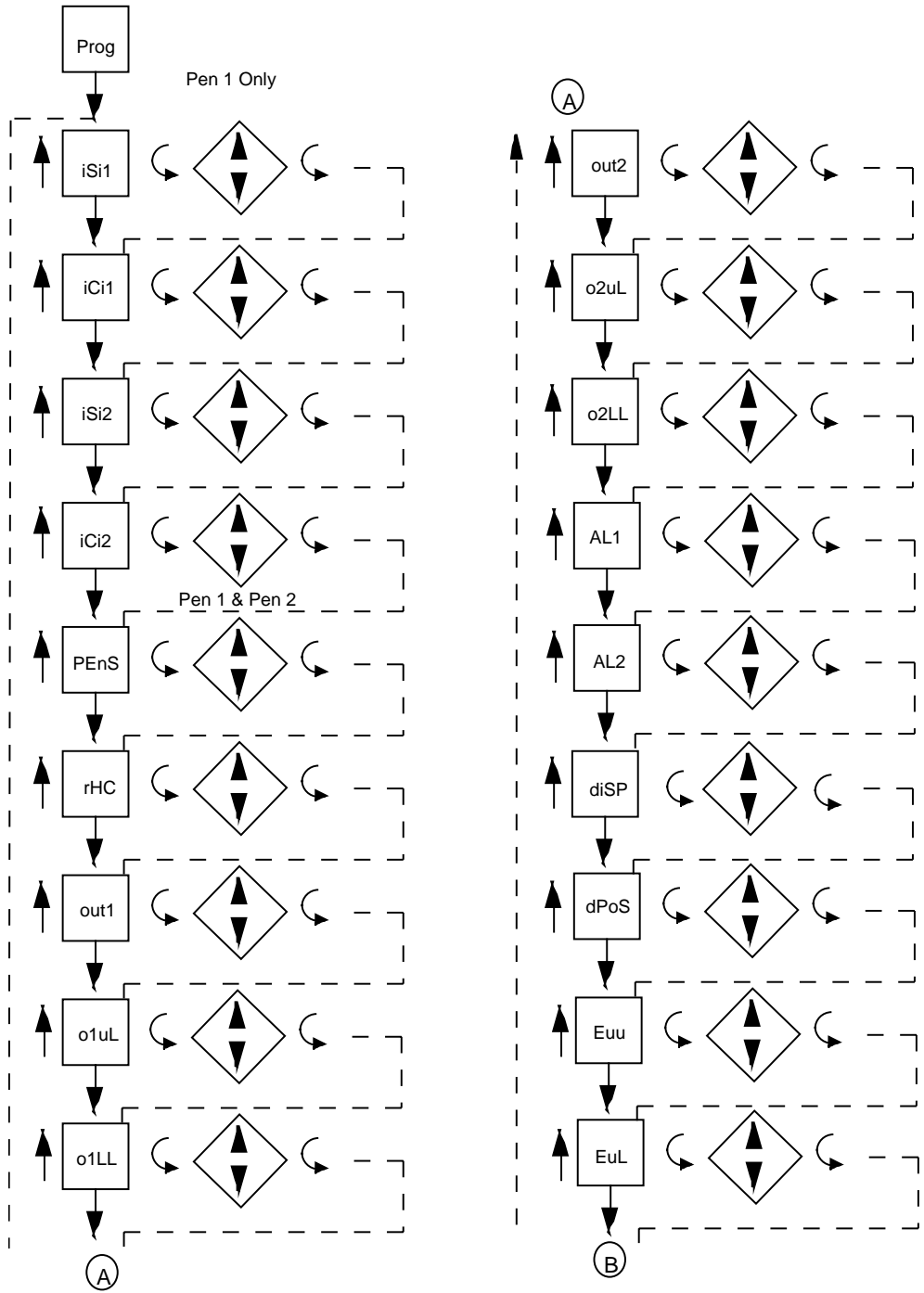



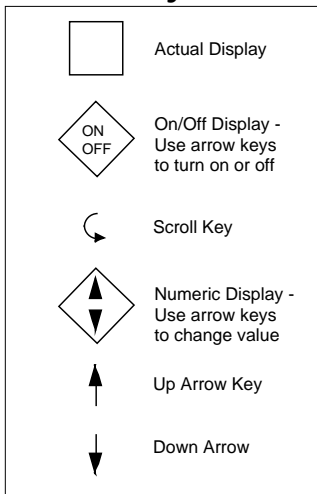

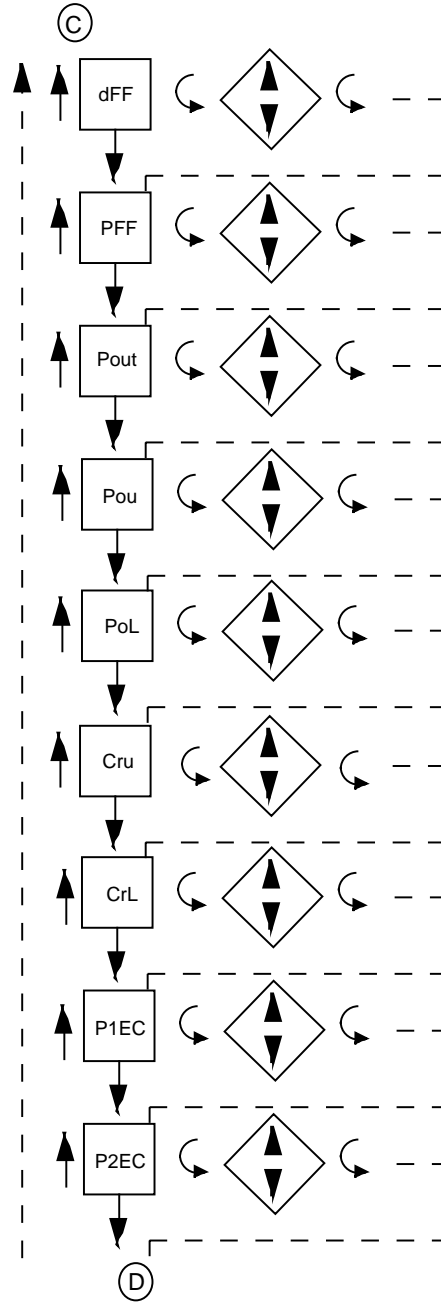
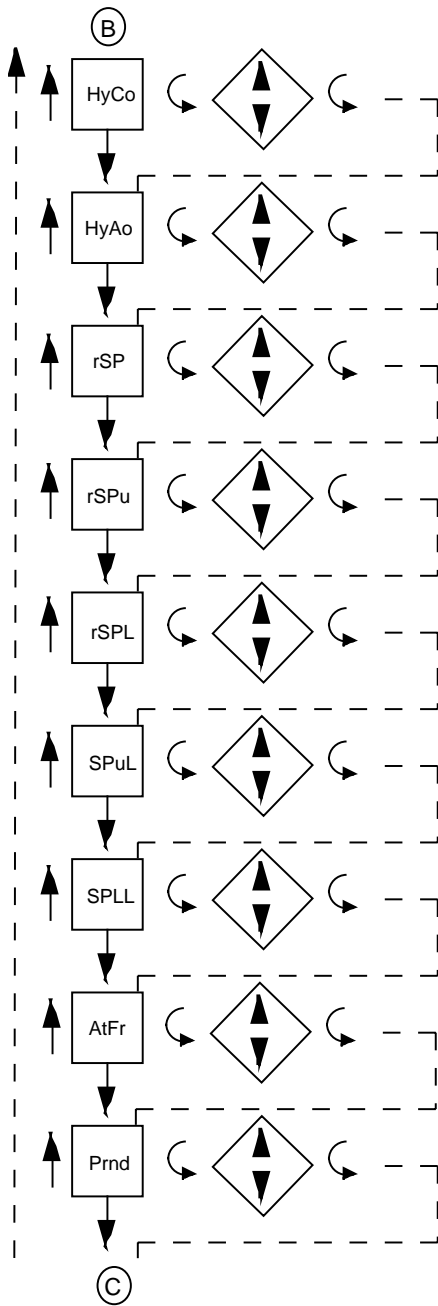

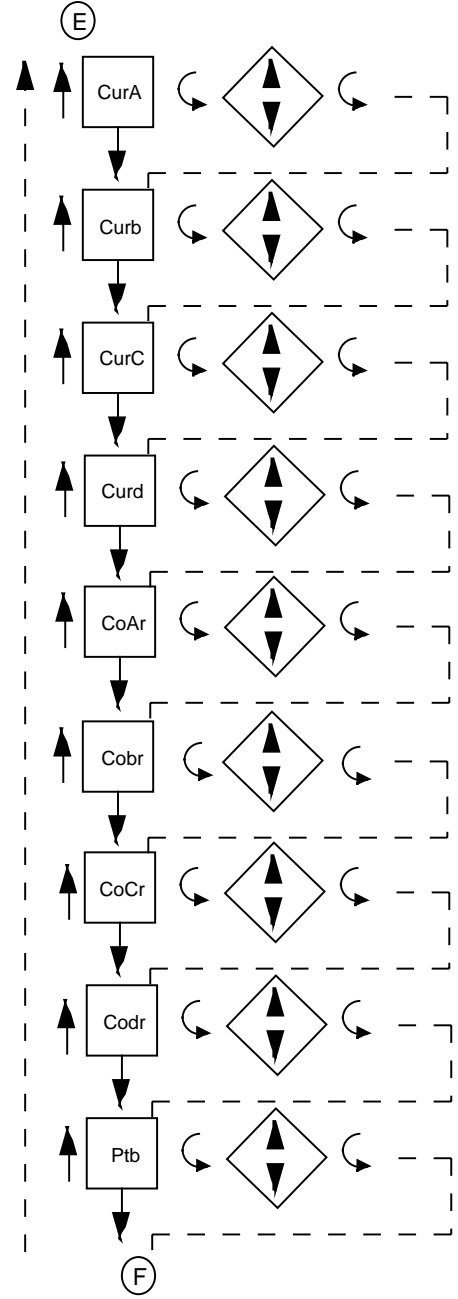
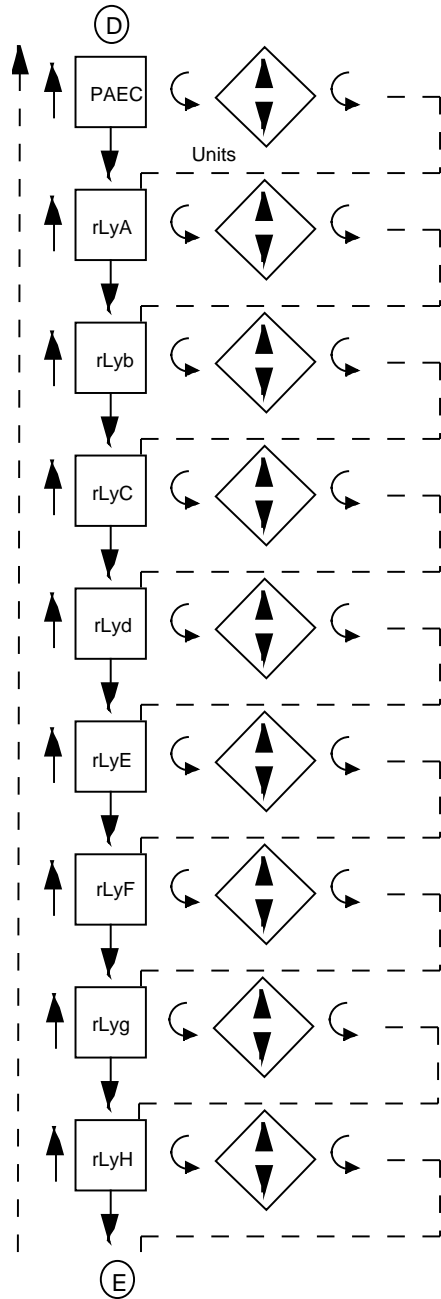
Key







Key

	Actual Display
	On/Off Display - Use arrow keys to turn on or off
	Scroll Key
	Numeric Display - Use arrow keys to change value
	Up Arrow Key
	Down Arrow

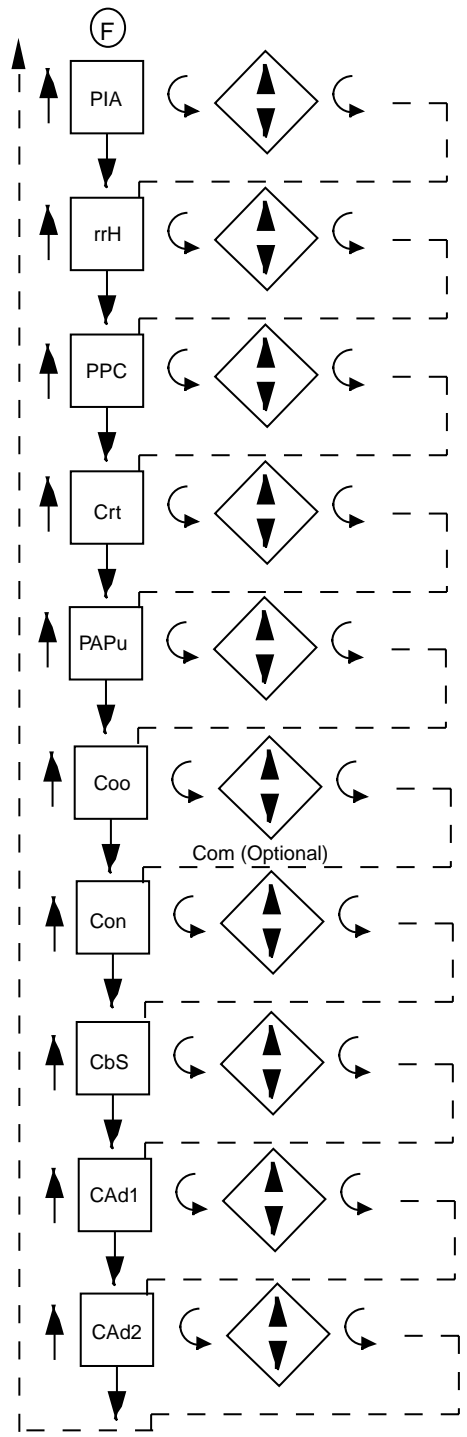

TABLE 3-1 PROGRAM MODE CONFIGURATION PROCEDURE

Press the SCROLL key until **Prog** is displayed. Press the DOWN key to enter the Program mode. Pen 1 will be displayed in the upper display. To enter the Pen 1 parameter, press the DOWN key. To enter the Pen 2 parameter, if provided, press the SCROLL key, then the DOWN key. To enter the unit parameter, press the SCROLL key with either Pen 1 or Pen 2 displayed until unit is displayed, then press the DOWN key. Press the SCROLL key to advance the display through the parameter codes and their values. Use the UP and DOWN keys to adjust the values. After adjusting a parameter, press the SCROLL key to proceed to the next parameter. After all selections have been made, press the UP key with a parameter in the display (not a setting) to exit the mode. For two pen instruments the parameters and values which are applicable to Pen 1 will appear in the upper display, then the parameters and values which are applicable to Pen 2 will appear in the lower display. Then the unit parameters and values will appear in the upper display.

For illustration purposes all available Program mode parameters have been listed. The parameters that will appear on the specific instrument will depend upon the model number (hardware configuration) of the instrument and on the parameter selections previously made.

For future reference record the parameter selections for the application in the “Your Setting” column and on the Software Reference Sheet in Appendix E (page 80).

To prevent unauthorized changes to the Program mode, the mode can be disabled (turned off) in the Enable mode.

STEP	DESCRIPTION	DISPLAY CODE	AVAILABLE SETTINGS	FACTORY SETTING	YOUR SETTING
1	Input Select TB 4	iSi1	0=J T/C degrees C 1=J T/C degrees F 2=K T/C degrees C 3=K T/C degrees F 4=T T/C degrees C 5=T T/C degrees F 6=R T/C degrees C 7=R T/C degrees F 8=S T/C degrees C 9=S T/C degrees F 10=E T/ C degrees C 11=E T/C degrees F 12=B T/ C degrees C 13=B T/C degrees F 14=N T/ C degrees C 15=N T/C degrees F 16=C T/ C degrees C 17=C T/C degrees F 20=RTD degrees C 21=RTD degrees F 30=0 to 5 VDC/0 to 20mA 31=1 to 5 VDC/4 to 20mA	21	
	Note:		Fault Detection is not functional for 0-5V or 0-20mA inputs.		
2	Input Correction TB 4	iCi1	-300.0 to +300.0 degrees -9999 to +9999 units	0.0	
3	Input Select TB 5	iSi2	0=J T/C degrees C 1=J T/C degrees F 2=K T/C degrees C 3=K T/C degrees F 4=T T/C degrees C 5=T T/C degrees F 6=R T/C degrees C 7=R T/C degrees F 8=S T/C degrees C 9=S T/C degrees F 10=E T/ C degrees C 11=E T/C degrees F	21	

STEP	DESCRIPTION	DISPLAY CODE	AVAILABLE SETTINGS	FACTORY SETTING	YOUR SETTING
			12=B T/ C degrees C 13=B T/C degrees F 14=N T/ C degrees C 15=N T/C degrees F 16=C T/ C degrees C 17=C T/C degrees F 20=RTD degrees C 21=RTD degrees F 30=0 to 5 VDC/0 to 20mA 31=1 to 5 VDC/4 to 20mA		
Note:	Fault Detection is not functional for 0-5V or 0-20mA inputs.				
4	Input Correction for TB 5	iCi2	-300.0 to +300.0 degrees -9999 to +9999 units	0.0	
5	Pen Select	PEnS	1=Dry Bulb Temperature 2=Wet Bulb Temperature 3=Relative Humidity	<i>Pen 1=1</i> <i>Pen 2=2</i> <i>(if Provided)</i>	
6	Relative Humidity correction (PEns=3)	rHC	-10 to +10%	0	
7	Output 1 *	out1	0=None 1=On-Off- Direct 2=On-Off- Reverse 3=Time Proportioning- Direct 4=Time Proportioning -Reverse 5=Current Proportioning -Direct 6=Current Proportioning -Reverse 7=Position Proportioning (open)	0	
8	Output 1 Percent * Upper Limit (o1uL and o1LL will not be seen if out1 = 0,1,2)	o1uL	0 to 100 percent	100	
9	Output 1 Percent * Lower Limit	o1LL	0 to 100 percent	0	
10	Output 2 *	out2	0=None (PositionProportioning Direct Closed) 1=On-Off- Direct 2=On-Off- Reverse 3=Time Proportioning- Direct 4=Time Proportioning-Reverse 5=Current Proportioning- Direct 6=Current Proportioning -Reverse 7=Position Proportioning (Reverse/Closed)	0	
11	Output 2 Percent * Upper Limit (o2uL and o2LL will not be seen if out2 = 0,1,2,7)	o2uL	0 to 100 percent	100	
12	Output 2 Percent * Lower Limit	o2LL	0 to 100 percent	0	
13	Alarm 1 the Alarm Point is selected in the Tune mode	AL1	0=None 1=Process Alarm-Direct 2=Process Alarm-Revers 3=Deviation Alarm-Direct 4=Deviation Alarm-Reverse 5=Deviation Band Alarm-Open within band	0	

STEP	DESCRIPTION	DISPLAY CODE	AVAILABLE SETTINGS	FACTORY SETTING	YOUR SETTING
			6=Deviation Band Alarm-Closed within band		
14	Alarm 2	AL2	Same selections as Alarm 1	0	
15	Display Select *	diSP	1=Process value only 2=Process value/setpoint 3=Deviation only 4=Deviation and setpoint 5=Setpoint only	1	
16	Decimal Position Not Available if PEnS=3 for Relative Humidity	dPoS	0 to 3 0=None 1=One decimal place 2=Two decimal places 3=Three decimal places RTD and thermocouple inputs are limited to either 0 or 1 decimal positions	0	
17	Engineering Units Upper Value (Euu and EuL will be seen if the pen input select = 30,31)	Euu	-9999 to 9999	1000	
18	Engineering Units Lower Value	EuL	-9999 to 9999	0	
19	Hysteresis for * Control Outputs	HyCo	0 to 300 Width of Hysteresis Band (See page 72 for definition)	3	
20	Hysteresis for Alarm Outputs	HyAo	0 to 300 Width of Hysteresis Band (See page 72 for definition)	3	
21	Remote Setpoint * (Pen 2 only) (If rSP is set to zero then rSPo and rSPL are not seen)	rSP	0 to 2 0 = Not used 1 = 1 to 5VDC 2 = 0 to 5VDC	0	
22	Remote Setpoint * Upper Value (Pen 2 only)	rSPu	-9999 to 9999	302	
23	Remote Setpoint * Lower Limit (Pen 2 only)	rSPL	-9999 to 9999	-94	
24	Setpoint Upper Limit *	SPuL	-9999 to 9999	302	
25	Setpoint Lower Limit *	SPLL	-9999 to 9999	-94	
26	Automatic Transfer *	AtFr	0=No Automatic Transfer 1=Transfers when the process value goes below the setpoint 2=Transfers when the process value goes above the setpoint	0	
27	Process Rounding	Prnd	1 to 100 0=No rounding	0	

Note: When Pen Select **PEnS** is programmed to a 3 (RH), the decimal position **dPOS** value reverts to 0. All program and tune parameters should be reviewed to ensure that the values are correct. (ie: **Pb1**=10.0 will revert to **Pb1**=100)

STEP	DESCRIPTION	DISPLAY CODE	AVAILABLE SETTINGS	FACTORY SETTING	YOUR SETTING
28	Display Filter Factor	dFF	1 to 20 1= no averaging (number of scans averaged)	1	
29	Process Filter Factor	PFF	Same selection as dFF	1	
30	Process Value Output Retransmission (If Pout =0 then Pou and PoL will not display)	Pout	0=Not selected 1=Selected	0	
31	Process Output Upper Value	Pou	-9999 to 9999	2000	
32	Process Output Lower Value	PoL	-9999 to 9999	0	
33	Chart Range Upper Value	Cru	-9999 to 9999	100	
34	Chart Range Lower Value	CrL	-9999 to 9999	0	
35	Proportional * Output 1 Action on Error Condition (If out1 = 0,1,2 then P1EC will not be seen)	P1EC	0 to 100%	0	
36	Proportional * Output 2 Action on Error Condition (If out2 = 0,1,2,7 then P2EC will not be seen)	P2EC	0 to 100%	0	
37	Pen Action on Error Condition	PAEC	0 or 1 0 = Pen goes to 0 % of chart 1 = Pen goes to 100 % of chart	1	

* NOT AVAILABLE ON RECORDER ONLY INSTRUMENTS

Pressing the SCROLL key with the **PAEC** parameter value displayed in the Pen 1 window will advance the display of a single pen instrument to the unit parameters. Pressing the SCROLL key with the **PAEC** parameter displayed in the Pen 1 window of a two pen instrument will advance the display to be **PEns** in the Pen 2 window. The Pen 2 Program mode parameter selections can be made now. Pressing the SCROLL key with the **PAEC** parameter value displayed in the Pen 2 window will cause the display to advance to the unit parameters.

Unit Parameters

38	Relay A assignment	rLyA	0 to 14 * 0=Not assigned * 1=Assigned to Alarm 1-Pen 1 * 2=Assigned to Alarm 2-Pen 1 * 3=Assigned to Alarm 1-Pen 2 * 4=Assigned to Alarm 2-Pen 2 * 5=Assigned to Output 1-Pen 1 6=Assigned to Output 2-Pen 1 7=Assigned to Output 1-Pen 2 8=Assigned to Output 2-Pen 2 9=Assigned to Event 1 10=Assigned to Event 2	0	
----	--------------------	-------------	--	----------	--

* Recorder Only

STEP	DESCRIPTION	DISPLAY CODE	AVAILABLE SETTINGS 11=Assigned to Event 3 12=Assigned to Event 4 13=Assigned to Event 5 14=Assigned to Event 6	FACTORY SETTING	YOUR SETTING
39	Relay B Assignment	rLyb	Same selection as rLyA	0	
40	Relay C Assignment	rLyC	Same selection as rLyA	0	
41	Relay D Assignment	rLyd	Same selection as rLyA	0	
42	Relay E Assignment	rLyE	Same selection as rLyA	0	
43	Relay F Assignment	rLyF	Same selection as rLyA	0	
44	Relay G Assignment	rLyg	Same selection as rLyA	0	
45	Relay H Assignment	rLyH	Same selection as rLyA	0	
46	Current Output A Assignment	CurA	0 to 6 * 0=Not Assigned * 1=Assigned to Process * Value Output-Pen 1 2=Assigned to Process * Value Output-Pen 2 3=Assigned to Output 1-Pen 1 4=Assigned to Output 2-Pen 1 5=Assigned to Output1-Pen 2 6=Assigned to Output 2-Pen 2	0	
47	Current Output B Assignment	Curb	Same selection as CurA	0	
48	Current Output C Assignment	CurC	Same selection as CurA	0	
49	Current Output D Assignment	Curd	Same selection as CurA	0	
50	Current Output A Range	CoAr	0=0-20 mA 1=4-20 mA	1	
51	Current Output B Range	Cobr	Same selection as CoAr	1	
52	Current Output C Range	CoCr	Same selection as CoAr	1	
53	Current Output D Range	Codr	Same selection as CoAr	1	
54	Profile Time Base ***	Ptb	1=HHH.H Hours and Tentths 2=HH.MM Hours and Minutes 3=MM.SS Minutes and Seconds	3	
55	Power Interrupt Action ***	PIA	0=Goes to Off mode 1=Continues Profile where left off 2=Go into Hold where left off 3=Restart the Profile	1	

* Recorder Only

*** Profiler Only

STEP	DESCRIPTION	DISPLAY CODE	AVAILABLE SETTINGS	FACTORY SETTING	YOUR SETTING
56	Remote Run/Hold *** (optional)	rrH	0=Not used 1=Remote overrides keypad 2=Remote or keypad will cause hold	0	
57	Pen(s) Profile *** Configuration (only seen on 2 Pen instruments)	PPC	1 or 2 1=Pen 1 only Profile Control 2=Both pens Profile Control	1	
58	Chart Rotation Time	Crt	0.1 to 999.9 hours per rotation	1.0	
59	Pen Action on Power Up	PAPu	0=Pen(s) go to "Home" position (towards chart center) when powered up 1=Pen(s) remain in last position prior to power down	0	
60	Chart Operation in Off Mode	Coo	0=Chart continues rotating in the Off mode 1=Chart stops rotating while in the Off mode	1	

Communications Options Parameters

61	Communication Configuration	Con	0=Off 1=Monitor Mode (Read Only) 2=Normal Mode (Read and Write) 3=Total Access with Limit Checking 4=Total Access without Limit Checking	3	
62	Communication Bit Rate Selection Will not be seen if Con=0	CbS	1=300 2=600 3=1200 4=2400 5=4800 6=9600	6	
63	Communications Address-Pen 1 Will not be seen if Con=0	CAd1	0 to 99	1	
64	Communications Address-Pen 2 (If provided) Will not be seen if Con=0	CAd2	0 to 99	2	

* Recorder Only

*** Profiler Only

TUNE MODE FLOW CHART

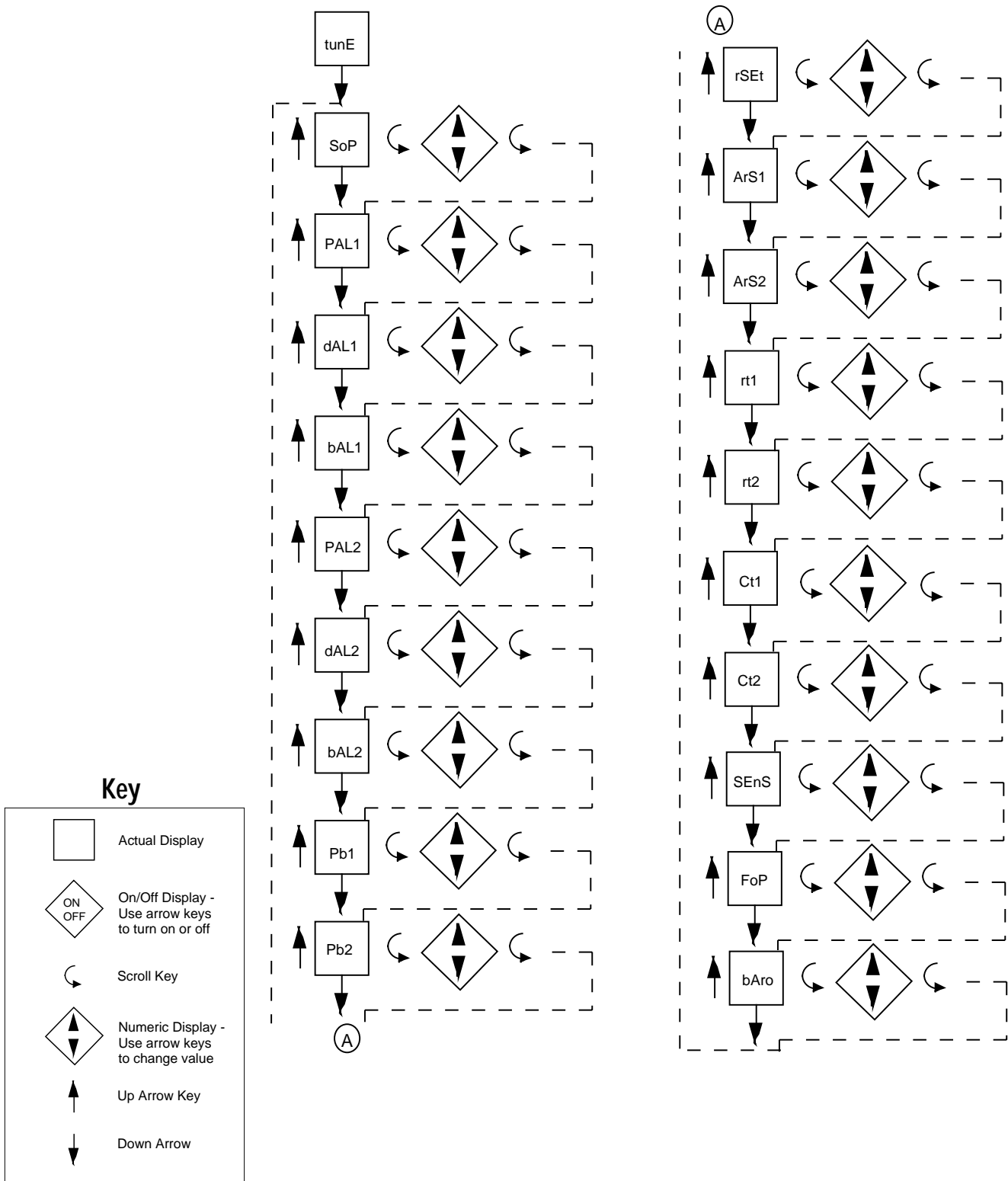

TABLE 3-2 TUNE MODE CONFIGURATION PROCEDURE (Not Available on Recorder Only Instruments)

The Tune mode allows the entry, review or altering of the process control Tune adjustments, the alarm setting(s) and the barometric pressure adjustment.

To enter the Tune mode, press and release the SCROLL key until **tunE** is displayed, then press the DOWN key. Press the SCROLL key to advance the display through the parameters and their values. Use the UP and DOWN keys to select (adjust) the values. Each time the DOWN key is pressed while a parameter code is being displayed, such as **dFF**, the next parameter code in the sequence will be displayed.

After selecting a parameter, press the SCROLL key to proceed to the next parameter. Pen 1 selections will appear in the Pen 1 window and the Pen 2 (if provided) selections will appear in the Pen 2 window after the Pen 1 parameters have displayed. In order to obtain the best relative humidity accuracy the current local barometric pressure value must be entered in the **bAro** parameter value. After all selections have been made, press the UP key with a parameter in the display (not a setting) to exit the mode.

For illustration purposes all available Tune mode parameters have been listed. The parameters that will appear on the specific instrument will depend upon the parameter selections previously made in the Program mode.

For future reference, record the parameter selections for the application in the "Your Setting" column and on the Software Reference Sheet in the Appendix E (page 80).

To prevent unauthorized changes to the Program mode, the mode can be disabled (turned off) in the Enable mode.

The Tune mode is adjusted on-line. The instrument will react to changes as they are made.

STEP	DESCRIPTION	DISPLAY CODE	AVAILABLE SETTINGS	FACTORY SETTING	YOUR SETTING
1	Second Output Position (Will not be seen if out2 =0,7)	SoP	-1000 to 1000 units	0	
2	Process Alarm 1 (The Alarm setting seen will depend upon the Alarm selected in the Program mode)	PAL1	-9999 to 9999 units	0	
3	Deviation Alarm 1	dAL1	-3000 to 3000 units	0	
4	Deviation Band AI 1	bAL1	1 to 3000 units	1	
5	Process Alarm 2	PAL2	-9999 to 9999 units	0	
6	Deviation Alarm 2	dAL2	-3000 to 3000 units	0	
7	Deviation Band AI 2	bAL2	1 to 3000 units	1	
8	Proportional Band Output 1 (Will only be seen if out1 =3,4,5,6,7)	Pb1	1 to 3000 units	100	
9	Proportional Band Output 2 (Will only be seen if out2 =3,4,5,6)	Pb2	1 to 3000 units	100	
10	Manual Reset (Will only be seen if Pb1/Pb2 were shown)	rSEt	-1500 to 1500 units	0	

STEP	DESCRIPTION	DISPLAY CODE	AVAILABLE SETTINGS	FACTORY SETTING	YOUR SETTING
11	Automatic Reset Output 1 - Integration (Will be seen if Pb1 was shown)	ArS1	0.0 to 100.0 repeats per minute	0.0	
12	Automatic Reset Output 2 - Integration (Will be seen if Pb2 was shown)	ArS2	0.0 to 100.0 repeats per minute	0.0	
13	Rate Output 1 Derivative (Will be seen if Pb1 was seen)	rt1	0.0 to 10.0 minutes	0.0	
14	Rate Output 2 Derivative (Will be seen if Pb2 was shown)	rt2	0.0 to 10.0 minutes	0.0	
15	Cycle Time Output 1 (Will be seen if out1=3,4,7)	Ct1	1 to 240 seconds	30	
16	Cycle Time Output 2 (Will be seen if out2=3,4)	Ct2	1 to 240 seconds	30	
17	Position Proportioning Sensitivity (Will be seen if out1=7 and out2=0,7)	SEnS	0.0 to 50.0 percent	1.0	
18	First Output Position (Will not be seen if out1=0)	FoP	-1000 to 1000 units	0	
19	Barometric Pressure (Will be seen if PEnS=3)	bAro	20.9 to 35.9 in. Hg.	29.9	

ALARM SET FLOW CHART

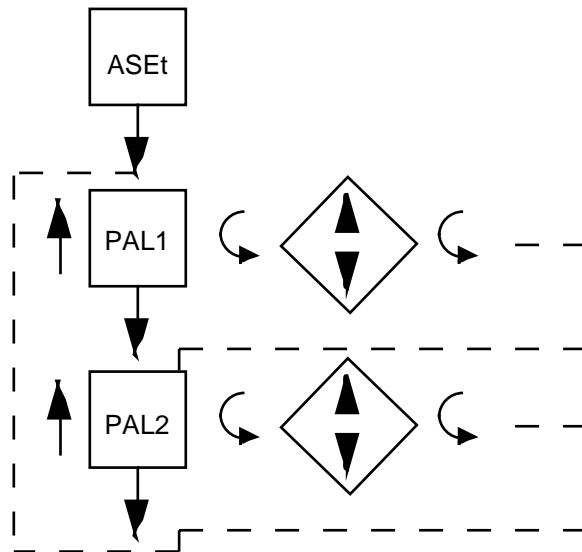

TABLE 3-3 ALARM SET MODE CONFIGURATION PROCEDURE

Press and release the SCROLL key until **ASeT** is displayed, then press the DOWN key. Press the SCROLL key to advance the display through the parameters and their values. Use the UP and DOWN keys to select (adjust) the values. After selecting a parameter, press the SCROLL key to proceed to the next parameter. Pen 1 selections will appear in the Pen 1 window and the Pen 2 (if provided) selections will appear in the Pen 2 window. After all selections have been made, press the UP key with a parameter in the display (not a setting) to exit the mode.

STEP	DESCRIPTION	DISPLAY CODE	AVAILABLE SETTINGS	FACTORY SETTING	YOUR SETTING
1	Process Alarm 1	PAL1	-9999 to 9999 degrees/units	0	
2	Process Alarm 2	PAL2	-9999 to 9999 degrees/units	0	

If **ASeT** does not appear on the display refer to the Enable mode section of this manual for directions on how to determine if the **ASeT** mode is enabled. If **ASeT** appears on the display, but pressing the DOWN key causes the display to change to **oFF**, this indicates that no alarm(s) have been selected in the Program mode.

ALARM OPERATION

There are two types available per pen, Process Direct or Process Reverse. These are selected in the Program mode.

Process Alarm Direct - the alarm will be ON if the process value is greater than the process alarm value selected in the Alarm Set mode.

Process Alarm Reverse - the alarm will be ON if the process value is less than the process alarm value selected in the Alarm Set mode.

The alarms will be active while the instrument is in the Operate mode.

Alarm output chatter can be reduced by using the hysteresis (adjusted in Program mode) to create a deadband around the alarm point.

TABLE 3-4 PROFILE ENTRY MODE CONFIGURATION PROCEDURE

Depress and release the SCROLL key until **PEnt** is displayed. Use the Down key to enter the Profile Entry mode. Depress the SCROLL key to scroll through the parameters and their values. Use the Up and Down keys to adjust the values. After adjusting a parameter, depress the SCROLL key to proceed to the next parameter. After all selections have been made, depress the Up key with a parameter in the display (not a setting) to exit the mode. For assistance in developing the Profile refer to Appendix F (page 83).

STEP	DESCRIPTION	DISPLAY CODE	AVAILABLE SETTINGS	FACTORY SETTING	YOUR SETTING
1	Profile Number	Pn	1 to 8	**	
2	Number of Segments	nS	0-6 segments	**	
Steps 3-21 are repeated for each segment					
3	Ramp Time	rt	0 to 9999 units per Ptb	**	
4	Setpoint-	SP	Setpoint at end of Ramp	**	
5	*Event Output 1	E1	on or off	**	
6	*Event Output 2	E2	on or off	**	
7	*Event Output 3	E3	on or off	**	
8	*Event Output 4	E4	on or off	**	
9	*Event Output 5	E5	on or off		**

STEP	DESCRIPTION	DISPLAY CODE	AVAILABLE SETTINGS	FACTORY SETTING	YOUR SETTING
10	*Event Output 6	E6	on or off		**
11	Soak Time	St	0 to 9999 units per PtB		**
12	*Event Output 1	E1	on or off		**
13	*Event Output 2	E2	on or off		**
14	*Event Output 3	E3	on or off		**
15	*Event Output 4	E4	on or off		**
16	*Event Output 5	E5	on or off		**
17	*Event Output 6	E6	on or off		**
18	Profile Loop Count	PLCt	0 to 9999, 0=continuous		**
19	Deviation Hold after Ramp Up	dhru	0 to 3000 units, 0=no auto hold		**
20	Deviation Hold after Ramp Down	dhrd	0 to 3000 units, 0=no auto hold		**
21	Profile End Control	PEnd	-1=Hold at last setpoint 0=Abort-all outputs off or at 0% Events off 1=Transfer to profile 1 2=Transfer to profile 2 3=Transfer to profile 3 4=Transfer to profile 4 5=Transfer to profile 5 6=Transfer to profile 6 7=Transfer to profile 7 8=Transfer to profile 8		**

After selecting the Profile End Control parameter value press the SCROLL key to advance the display to **Pn**. Press the UP key with **Pn** or any parameter code displayed to exit the Profile Entry Mode.

*Event outputs will remain in their current status during an error condition (ie: sensor break SnSr) and upon entering the Profile Continue mode **PCon** but will turn off when entering other non-control modes (ie: Program Prog mode).

**All values except Profile Loop Count (PLCt) are initialized to zero and all event outputs are initialized to Off, with the exception of the first profile. Profile Loop Count (PLCt) is set to 1.

The first profile has the number of segments initialized to zero, to turn the profile Off, but the profile has values stored in it for demonstration purposes. By setting the number of segments to two, the profile can be reviewed and/or executed.

PROFILE 1 VALUES FOR DEMONSTRATION PURPOSES

<u>Code</u>	<u>Value</u>	
rt	.10	Ramp Time
SP	100	Setpoint
E1	on	Event 1 on
E2	oFF	Event 2 off
E3	oFF	Event 3 off
St	.10	Soak Time
E1	oFF	Event 1 off

E2	on	Event 2 on
E3	oFF	Event 3 off
rt	.10	Ramp Time
SP	0	Setpoint
E1	oFF	Event 1 off
E2	oFF	Event 2 off
E3	on	Event 3 on
St	.10	Soak Time
E1	oFF	Event 1 off
E2	oFF	Event 2 off
E3	oFF	Event 3 off
PLct	1	Profile Loop Count
dhru	0	Deviation Hold after Ramp Up-None
dhrd	0	Deviation Hold after Ramp Down-None
PEnd	0	Profile End Control-Abort-oFF mode

TABLE 3-5 ENABLE MODE CONFIGURATION PROCEDURE

To enter the Enable mode, press the UP and DOWN keys while in **Ctrl** or **oFF** modes. All the display lamps will light. After 10 seconds the lamps will go out and **EnAb** will be displayed. Release the keys and the display will change to **EtSt**. Press and release the DOWN key and each mode to be enabled/disabled will be displayed,. With the enable mode prompt for the desired mode displayed press the SCROLL key to verify that the displayed mode is either **on** (enabled) or **oFF** (disabled). Press the DOWN key to turn off the mode,press the UP key to turn on the mode or press the SCROLL key to advance the display to the next enable mode prompt. Use the Your Setting column in the table to record your programming.

A hardware jumper located on the Controller Board (See Appendix A-1, page 68) can be used to lock/unlock the Enable mode. When the jumper is moved to the locked position, entry into the Enable mode is not possible until the jumper is moved to the unlocked position.

1	Test Mode	EtSt	on or oFF	oFF
2	Calibration Mode	ECAL	on or oFF	oFF
3	Program Mode	EPro	on or oFF	on
4	Tune Mode	Etun	on or oFF	on
5	Manual (Stby) Mode	ESby	on or oFF	on
6	Profile Continue Mode	EPC	on or oFF	oFF
7	Profile Entry Mode	EPE	on or oFF	on
8	Setpoint Change	ESPC	on or oFF	on

ENABLE MODE FLOW CHART

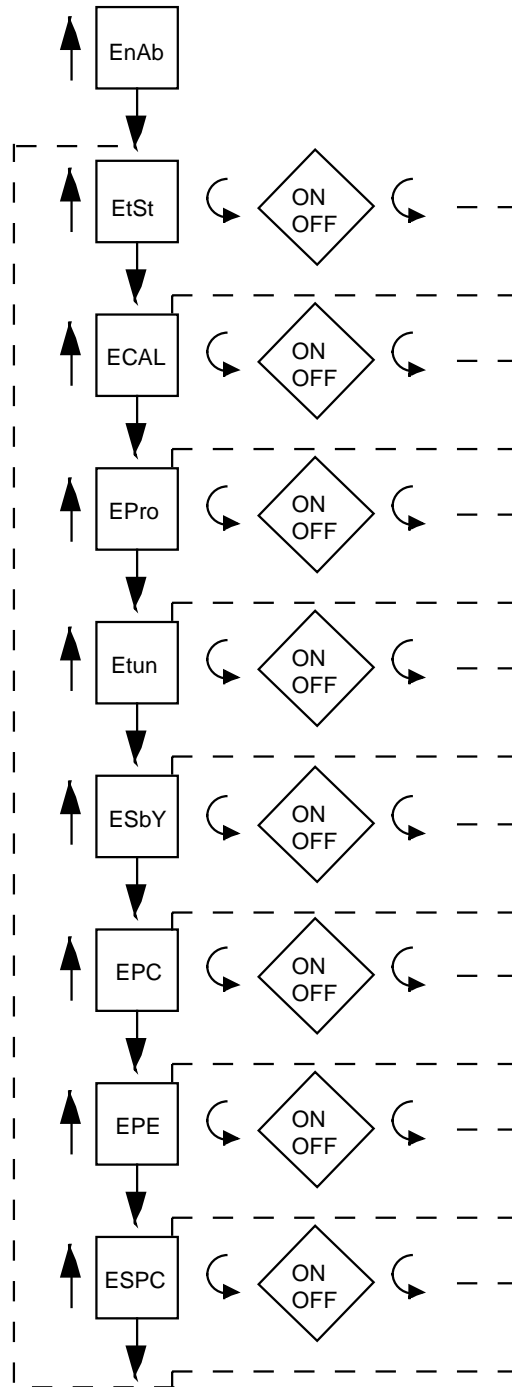

Key

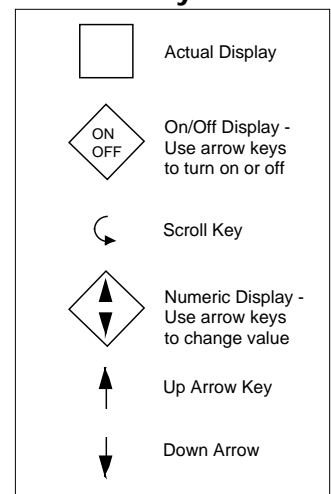

Operation 4.1

4.1.1 OFF MODE

In the Off mode, the instrument control and alarm function(s) are turned off. Process re-transmission signals remain active. The chart rotation can be selected in the Program mode to stop or continue to rotate when the instrument is in the Off mode. The pen(s) will remain active. The Off mode can be entered by pressing and releasing the SCROLL key until the display reads **oFF**, then pressing the DOWN key. The display will read **oFF** and then current process variable at two second intervals. Entering the Off mode of a dual pen instrument will cause both pens to enter the Off mode. The second pen display will be blank as the upper display reads **oFF** and displays the process value for the second pen at the same time as the upper display.

4.1.2 CONTROL MODE

In the Control mode, the instrument control function(s) and alarm(s) are actively responding to the process variable as selected in the Program and Tune modes and the chart will be rotating at the rate selected. The Control mode allows setpoint changes from either local setpoint (standard) adjustment by an operator at the front keypad or from a remote setpoint source (optional). Other operations in the Control mode include a lamp test and proportional output display.

4.1.2.1 LOCAL SETPOINT OPERATION

Single Pen Instruments: The instrument must be in the Control mode to allow setpoint value to be displayed and adjusted. In the Control mode, to view the setpoint, press and release the UP or DOWN key. The green LED under the SP label will light to indicate that the displayed value is the setpoint. To change the setpoint value, press and hold the appropriate key (UP or DOWN). Press and hold the UP key to increase the setpoint or press and hold the DOWN key to decrease the setpoint. The setpoint will change slowly at first then faster as the key is held pressed. If the setpoint will not increase, check the Program mode to see that you are not trying to increase the setpoint above the setpoint upper limit **SPuL**. If the setpoint will not decrease, check the Program mode to see that you are not trying to decrease the setpoint below the setpoint lower limit **SPLl**. If the setpoint will not increase or decrease check that the Setpoint Change mode is on in the Enable mode.

Dual Pen Instruments: The setpoint of each instrument can be reviewed separately. PEN 1: To review and change the local setpoint for Pen 1 press the UP key. The green LED in the upper display will light indicating that the setpoint value is displayed. The setpoint can now be raised by pressing and holding the UP key or decreased by pressing the DOWN key. PEN 2: The setpoint for Pen 2 is viewed and changed in the same manner, except the DOWN key must be pressed to access the Pen 2 setpoint. The setpoint will change slowly at first then faster as the key is held pressed. If the setpoint will not increase check the Program mode to see that you are not trying to increase the setpoint above the setpoint upper limit **SPuL**. If the setpoint will not decrease check the Program mode to see that you are not trying to decrease the setpoint below the setpoint lower limit **SPLl**. If the setpoint will not increase or decrease check that the Setpoint Change mode is on in the Enable mode.

4.1.2.2 REMOTE SETPOINT OPERATION (Optional)

Dual Pen Instruments: The Remote Setpoint Option is only available on the second pen of a dual pen. To use this option, if available, the Program mode selections must be properly made. The Remote Setpoint parameter **rSP** must be selected as a 1 or 2 as needed. The Remote Setpoint Upper **rSPu** and Lower **rSPL** parameters need to be selected for the application. Pen Profiling Configuration parameter **PPC** must be selected as 1 Pen Profiling only. The Remote Setpoint signal is connected to the TB5 terminals as shown in Section 2 of the manual.

Digital Communications: The setpoint can be adjusted from a supervisory computer system. Dual pen instruments are capable of having independent setpoint adjustments for each pen.

4.1.2.3 PROFILE CONTROL OPERATION

To start a profile press and release the Scroll key until the number of the profile that is to be started is displayed. With the desired profile number displayed press either the DOWN or the RUN/HOLD to start the profile. **RUN** will be displayed for about 2 seconds to indicate that the profile is starting. The status lamps will indicate which segment is active and if in the ramp or soak portion of the segment.

To stop a profile that is running, press the RUN/HOLD key. The display will show **hold** for about 2 seconds, then the process value for about 2 seconds and then continue to display this sequence. The profile timer will stop but the control, alarm and event outputs will remain active. The profile can be restarted by pressing the RUN/HOLD key. To exit the profile, press and release the SCROLL key until the display shows **oFF** or **Ctrl**, then press the DOWN key. Pressing the DOWN key with **oFF** displayed will cause the control alarm and events to be turned off. Pressing the DOWN key with **Ctrl** displayed will abort the profile and begin controlling the process automatically at the last setpoint value. Event outputs remain in the state (on or off) they were in prior to aborting the profile.

While a profile is running, it is possible to display additional profile status information. To activate the Profile Execution Status Display sequence, hold the DOWN key and press the SCROLL key. This will cause the display to sequence through the following series of display codes and values:

<u>Display Code</u>	<u>Description</u>	<u>Value</u>
Pn	Profile Number	Actual Profile Number
tr	Time remaining in current Ramp or Soak	Actual time remaining value (in whatever units were configured in the Program mode for Ptb)
E1, E2, E3	Event 1-3 status (if applicable)	on or oFF
SP	Current Setpoint	Actual Setpoint Value
ProC	Current Process Value	Actual Process Value
PLCt	Profile Loop Count remaining	Profile Loop Count Value

Each code or value will only be displayed if they are appropriate. Each code or value will be displayed for one second. This sequence will continue until any key is depressed.

To start a profile running at some point within the profile other than the start can be accomplished by using the Profile Continue mode. Press and release the SCROLL key until the display is **PCon**, then press the DOWN Key. The display will be **Pn**, adjust the profile parameter values as needed in the Profile Continue Configuration mode, then press the RUN key. The instrument will execute the profile selected as directed by the information entered in the Profile Continue mode. The parameter values seen in the Profile Continue mode will indicate the values of the last active profile.

TABLE 4-1 PROFILE CONTINUE MODE

STEP	DESCRIPTION	DISPLAY CODE	ACTION
1.	Profile Number	Pn	Press the SCROLL key to see the number of the last active profile.
2.	Profile Number Value	X	If necessary, use the UP or DOWN key to change the profile number to the desired value, then press the SCROLL key.
3.	Segment Number	Sn	Press the SCROLL key to see the number of the last active segment.

4.	Segment Number Value	X	If necessary, use the Up or Down key to change the segment number to the desired value, then press the SCROLL key. DO NOT SET THIS VALUE TO 0 AND ATTEMPT TO RUN THE PROFILE. AN ERROR 19 CODE WILL DISPLAY AND THE PROFILE WILL NOT RUN.
5.	Ramp Time Remaining	rtr	Press the SCROLL key to see the Ramp Time Remaining value.
6.	Ramp Time Remaining Value	X	If necessary, use the UP or DOWN key to adjust the Ramp Time Remaining value, then press the SCROLL key. If the time remaining is set to 0 when the SCROLL key is pressed the Soak Time Remaining code will be displayed. If the time remaining is greater than 0 then the display will advance to the events, if programmed. If no events are programmed, the display will advance to Profile Loop Count.
7.	Soak Time Remaining	Str	Press the SCROLL key to see the Soak Time Remaining value of the last active profile.
8.	Soak Time Remaining Value	X	If necessary, use the UP or DOWN key to adjust the Soak Time Remaining value, then press the SCROLL key.
9.	Event(s)	E1-E6	If any event outputs have been selected in the Program mode then each event number selected will be displayed in sequence. Press the SCROLL key to see the status of the event(s).
10.	Event(s) Status	on/off	If necessary, use the UP key to turn on an event that is off or the DOWN key to turn off an event that is on. Press the SCROLL key to see the next event number. After the last event status is selected pressing the SCROLL key will advance the display to PLCt .
11.	Profile Loop Count Remaining	PLCt	Press the SCROLL key to see the Profile Loop Count Remaining for the last active profile.
12.	Profile Loop Remaining	X	If necessary, use the UP or Down key to adjust the Profile Loop Count Remaining value.

To start the profile running press the RUN/HOLD key while in the Profile Continue mode. The profile selected will start at the point selected.

4.1.2.4 ON-OFF CONTROL

On-Off control can only be implemented on controllers provided with SPST relay or SSR driver output(s). On-Off operation can be assigned to either or both output 1 and 2 for each pen. The On-Off control can be selected as direct or reverse acting. Direct action is typically used in cooling applications. The output device will turn on when the process value is greater than the setpoint. Reverse action is typically a heating application. The output device will turn on if the process value is below the setpoint. A hysteresis adjustment is provided for On-Off outputs on each pen. This adjustment is in terms of degrees/engineering units and defines the width of the hysteresis bandwidth about the setpoint. This parameter may also be referred to as a dead band. Relay chatter can be eliminated by proper adjustment of this parameter. When operating in On-Off control, the control algorithm will turn the output on or off depending upon the setpoint, the relative position of the process value, and the hysteresis adjustment. The respective **OUT 1** or **OUT2** indicator for the respective pen will illuminate to indicate that the output device is on.

4.1.3 MANUAL MODE FOR PROPORTIONAL OUTPUTS

Manual adjustment of the proportional output(s) can be used to test the operation of the output(s), while tuning to establish basic process control, or to provide control of the proportional output(s) during the occurrence of certain error conditions.

Note: The proportional output(s) do not change automatically in response to changes in the process while in the Manual mode. Be sure to pay close attention to the process to avoid damage.

To enter the Manual mode, press and release the AUTO/MAN key for the specific pen. If the Standby mode is **on** in the Enable mode and a control output is selected for proportional control, the instrument will enter the Manual mode. The Manual mode status LED will light for that pen to indicate that the Manual mode is in use. Shifting from the Control to the Manual mode is bumpless. The proportional output(s) will stay at the last value(s) calculated by the control algorithm. **Po1** will appear on the display if output 1 is a proportional output or **Po2** if output 1 is not a proportional control.

In order to vary a proportional output value, press and release the SCROLL key until the display code for the output is displayed **Po1** or **Po2**. Press the SCROLL key to see the percentage of output value. Press the UP key to increase the output percentage value. Press the DOWN key to decrease the output percentage value.

If no keys are pressed, the display will sequence through the following displays:

Po1 if output 1 is 3, 4, 5, 6, 7 then the output 1 percentage of output value.

Po2 if output 2 is 3, 4, 5, 6 then the output percentage of output value.

Proc will be displayed then current process value for that pen.

In order to change a proportional value once the cyclic display begins, press and release the UP or DOWN key then press the SCROLL key until the display code for the output is displayed **Po1** or **Po2**. Press the SCROLL key again to see the percentage of output value. Press the UP key to increase the output percentage value. Press the DOWN key to decrease the output percentage value.

To return to the Control mode of operation from the Manual mode, press the specified AUTO/MAN key. If the Automatic Transfer feature is selected in the Program mode, the instrument will switch from the Manual mode to the Control mode when the process value reaches the setpoint value.

Alarm Operation 4.2

There are two alarms available per pen. The type of alarm is selected in the Program mode as follows:

1. Process Alarm Direct - the alarm will be **on** if the process value is greater than the process value selected.
2. Process Alarm Reverse - the alarm will be **on** if the process value is less than the process value selected.
3. Deviation Alarm Direct - the alarm will be **on** if the process value is greater than the setpoint plus the deviation value selected.
4. Deviation Alarm Reverse - the alarm will be **on** if the process value is less than the setpoint plus the deviation value selected.
5. Deviation Band Alarm Open Within - the alarm will be **on** if the process value is greater than one half the deviation band alarm values selected above or below the setpoint.

6. Deviation Band Alarm Closed Within - the alarm will be **on** if the process value is less than one half the deviation band value selected above or below the setpoint.

The alarms will be active while the instrument is in the Control mode. Relay and solid state relay drivers can be assigned to provide output capability for the alarm functions.

The alarm value (Process deviation or bandwidth) is selected in the Tune mode.

Alarm output chatter can be reduced by using the hysteresis for the alarm outputs adjustable in the Program mode to create a deadband around the alarm point.

Tune Mode Operation 4.3

Proportional output controllers may require the adjustment (tuning) of the PID and other related parameters. This provides a means for the instrument's control algorithm to be adjusted to meet specific application requirements.

4.3.1 SYSTEMATIC TUNING METHOD

1. Changes in tuning parameters should be made one at a time.
2. After making any changes in tuning parameters, a disturbance should be introduced into the process so that the process reaction may be observed. This process reaction, or recovery, will tell whether the tuning parameters provide the desired control. It is usually easiest to make a step change in setpoint to introduce this disturbance.
3. The change in setpoint, or disturbance, referenced above should be large enough to cause an observable deviation of process from setpoint. However, this change should not be so large that it will cause the controller output to proceed to either extreme limit.
4. Controller tuning for optimal control is not hard and fast, **BE PATIENT**: The process will take a certain amount of time to react to the setpoint changes during tuning. The amount of time depends upon the specific process, however, a period of 8 to 12 minutes should be allowed between changes. The important point to remember is to allow the process to react completely, do not rush through tuning of the controller. If the complete process reaction is not observed, optimum control may never be achieved.
5. Time Proportioning control output(s) require the cycle time be adjusted for the application. Short cycle times typically result in the most accurate process control, but will cause the quickest wear out of any mechanical components.
6. Leave all other tuning parameters (except for the alarm and barometric pressure settings) at the factory default settings. Obtain the best possible process reaction by adjusting the Proportional Bandwidth parameter. The setting that achieves the best response for the process should be left in the controller programming, and should be noted on the Software Reference Sheet in Appendix E (page 80).
7. If there are to be no setpoint or load changes in the process, the Proportional Band adjustment may be all that is necessary for proper control. If an offset still exists (the process does not settle out at setpoint with the best possible proportional band adjustment) Manual Reset may be added to eliminate this offset.
8. Auto Reset may be added to eliminate offsets and improve response to setpoint and load changes. Increase Auto Reset from 0 in 0.2 increments. Start with a small amount. Increase this increment if there is no apparent reaction. Remember to allow the process 8 to 12 minutes to react to any changes.
9. If necessary, Rate may be added. Rate is a dynamic tuning parameter. Rate may be required to compensate for process lags or to help inhibit reset windup when a large amount of Auto Reset (4 or 5 repeats per minute) is being used.
10. Controller tuning is not hard and fast. It may be necessary to adjust the tuning parameters over a period of time to obtain optimal control of the process.

4.3.2 ZIEGLER NICHOLS TUNING METHOD

This procedure has been determined empirically to yield 1/4 wave decay tuning parameters that are determined by watching the system in a sustained oscillation (curve C, page 49, the ultimate proportional band and ultimate time period) and then using these values from this sustained oscillation to calculate ideal parameters.

To aid in determining the process oscillation, the instrument configuration parameters can be adjusted. By reducing the chart upper value **CrU** and increasing the chart lower value **CrL** the resolution of the oscillation can be better observed. Also the chart rotation time **Crt** can be reduced to improve the observation of the oscillation cycle times.

Determining Ultimate Proportional Band and Ultimate Time Period

1. Set Manual Reset **rSet** to 0.0, set **ArS1** and **ArS2** to 0.0 and set **rt1** and **rt2** to 0.0.
2. Enter the Control mode of operation, observe the process reaction.
3. Set the Proportional Band (PB) at 100 and upset the process and observe the response. One easy method for imposing the upset is to move the setpoint for a few seconds and then return it to its original value.
4. Achieve a response curve similar to the sustained oscillation (curve C), this is the Ultimate Proportional Band (UPB) and Ultimate Time Period (UTP).
 - a) If the response curve from step 3 does not dampen, as in Curve A from the drawing, the PB is too low. The PB should be increased and step 3 repeated.
 - b) If the response in step 3 dampen, the PB is too high. The PB should be decreased and step 3 repeated.

These values obtained for Ultimate Proportional Band (UPB) and Ultimate Time Period (UTP) are used to calculate ideal P, PI, PD, PID tuning parameters using the following Ziegler-Nichols equations:

Proportional only control (P) -

$$P (Pb) = 2 \times UPB \text{ (degrees or units)}$$

Proportional plus automatic reset (PI) -

$$P (Pb) = 2.2 \times UPB \text{ (degrees or units)}$$

$$I (ArSt) = 1.2 / UTP \text{ (repeats per minute)}$$

Proportional plus derivative (or rate) (PD) -

$$P (Pb) = 1.7 \times UPB \text{ (degrees or units)}$$

$$D (rAtE) = UTP / 8 \text{ (minutes)}$$

Proportional plus automatic reset plus derivative (PID) -

$$P (Pb) = 1.7 \times UPB \text{ (degrees or units)}$$

$$I (ArSt) = 2 / UTP \text{ (repeats per minute)}$$

$$D (rAtE) = UTP / 8 \text{ (minutes)}$$

If an overdamped response is desired, multiply the proportional band by two.

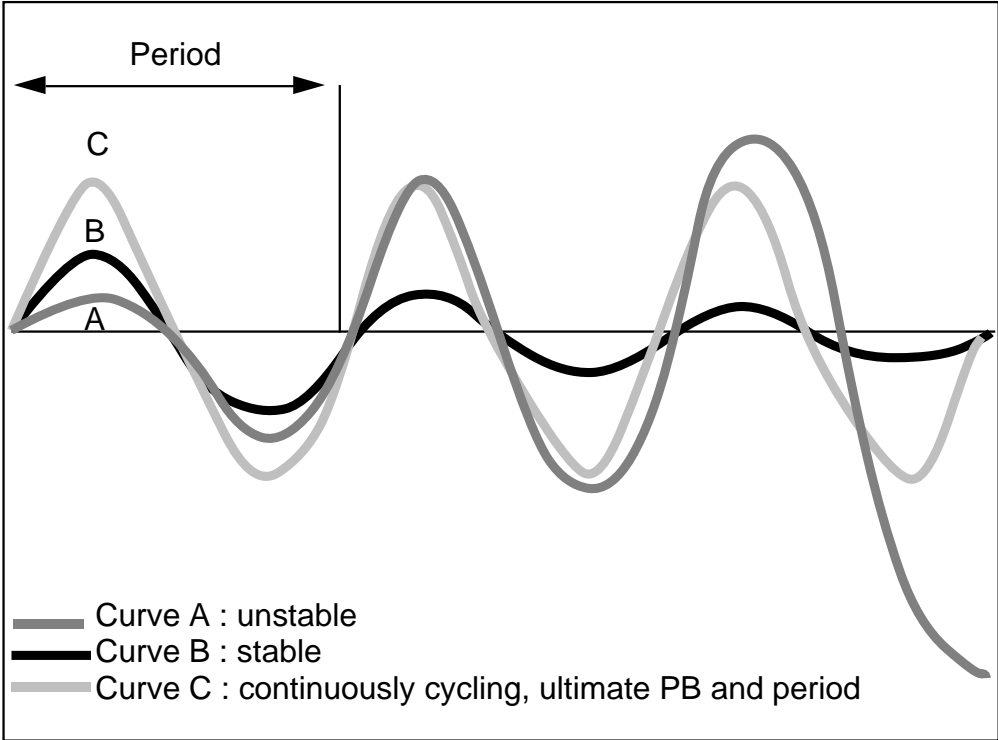

Service 5.1

This section contains information regarding calibration and test procedures that can be performed in the field as well as items concerning the normal maintenance of the instrument.

Changing Charts 5.2

Chart changes may be done while in the normal operating mode.

CAUTION: The chart flange assembly pin is sharp to perforate the chart. Use caution while installing the chart to avoid coming into contact with the pin.

1. Depress and hold the UP and DOWN keys for between 2 and 3 seconds. Immediately after depressing the keys, the unit will do a Lamp Test with all LED segments and indicators lighted on the upper (and lower) display.
2. After 2-3 seconds, the display will show **Cchg**, the pen(s) will move to and remain at a point above the top graduation on the chart and the chart will stop rotating. All other functions remain active (Control, Display, etc).
3. Open the instrument door, snap up the chart hold down lever on the chart flange assembly, gently lift the pen(s) and remove old chart.
4. With the pen(s) held up, install new chart. Be sure to line up the chart time line so that the current time is aligned with the time setting mark on the chart platen.
5. Snap down chart hold down lever and close the instrument door.
6. Depress and hold the UP and DOWN keys for between 2 and 3 seconds. Immediately after depressing the keys, the unit will do a Lamp Test with all LED segments and indicators lighted on the upper (and lower) display.
7. After 2-3 seconds, the display will show **Cchg** momentarily, then the pen(s) position and chart rotation will be restored.

Changing Pens 5.3

Open the instrument door. Refer to Figure 5-1 for pen changing procedure. This procedure is also provided on a label on the instrument chart platen. Be sure to replace the pen cartridge with the same type (color) that was removed. Be careful not to bend the pen arm while changing the pen.

FIGURE 5-1
Changing Pens

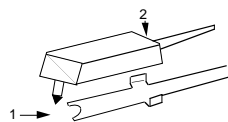

To install pen, slide pen into holder (1) and push down (2) as shown by arrows.

For replacement pen cartridges order:

Green #60500401
Red #60500402

(Pens are sold in lots of 5 each)

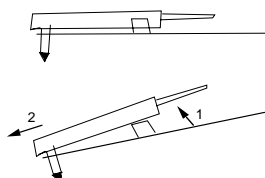

To remove pen, pull up at back end (1) and push out.

Calibration 5.4

CAUTION: Do not attempt any calibrations without the proper test equipment that meets or exceeds the specifications listed.

Press and release the SCROLL key until **CAL** appears on the display, then press the DOWN key to enter the mode. The display will change to **CAL1**. Press the SCROLL key to advance the display to the other calibration modes available. For two pen units, **CAL2** and **CAL3** will only need to be performed on TB 4 to calibrate both TB4 and TB5 inputs. Both TB 4 and TB 5 inputs must be calibrated for RTD inputs. Table 5-1 provides a listing of field calibration routines. All instruments are calibrated prior to shipment from factory.

CALIBRATION FLOW CHART

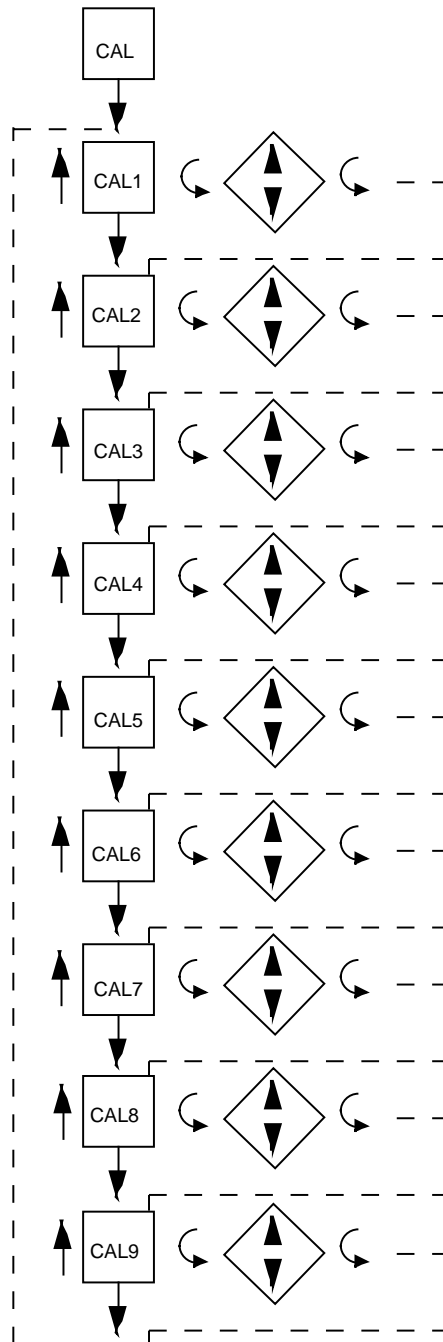
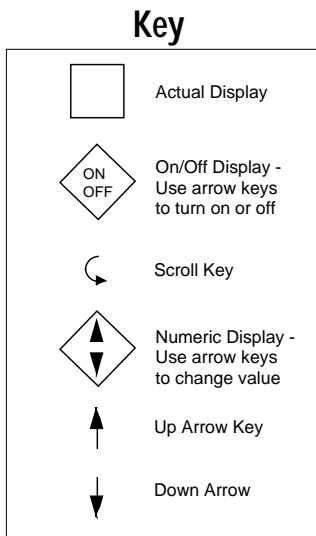

TABLE 5-1 CALIBRATION PROCEDURES

Calibration Procedure	Description
CAL 1	Reinitialization of Program and Tuning mode values. All parameters are reset to factory set default values.
CAL 2	Main calibration necessary for all input types.
CAL 3	Cold Junction Compensation calibration used to correct for component variation in the CJC circuit. Necessary for thermocouple inputs.
CAL 4	Cold Junction Utility, displays temperature the cold junction compensator is sensing. No adjustment is made with this procedure.
CAL 5	RTD input calibration. Necessary to be performed on both terminal boards.
CAL 6	Cold Junction Compensation on/off. Used for validating thermocouple inputs with a millivolt source. (Non temperature compensating)
CAL 7	Factory use only
CAL 8	Reinitialization of all profile information.
CAL 9	Pen position calibration used to calibrate pens to chart.

5.4.1 CAL 1 PARAMETER RE-INITIALIZATION

This routine is used to clear all information in the Program and Tune modes. All parameters will be reset to default values. **Before performing this procedure make sure that the Program and Tune values are written down so that they can be re-entered after Calibration 1 is completed. No test equipment required.**

With **CAL 1** displayed, press and hold the DOWN key, then press the SCROLL key. The display will momentarily blank; Release the keys. Upon completion of the routine **CAL 1** will reappear on the display.

5.4.2 CAL 2 MAIN CALIBRATION

This routine determines and saves calibration values which correct for component variations relating to the basic measuring function of the unit. A 12.4 mVDC \pm .01mVDC source is required for testing. **Make sure that the Processor board jumpers JU4 and JU5 are in the non-volt positions. See Appendix A-1 (page 68) for proper positioning. After completing CAL2, be sure to reposition these jumpers to the appropriate position for your input.**

With **CAL 2** displayed, press and hold the DOWN key, then press the SCROLL key. Release the keys when the instrument displays **hLd1**. Short both input terminals, TB4 & TB5, or apply 0.00, \pm .01 mVDC to TB 4 terminals 1 and 2. Press the DOWN key and **dELy** will appear for 10 seconds, then **SCAn** will appear for 10 seconds. A calibration reference number will then appear; this should be 0 ± 50 . If this number falls outside these limits, press the SCROLL key and **CAL 2** will be displayed. Perform the calibration again. Repeat the calibration until the number falls within the tolerance limits. If the number remains outside the limits, check the connections and try the calibration again. If the number does not approach the tolerance limits contact the nearest representative or the factory for assistance. With an acceptable reference number on the display, remove the short and connect a 12.4, \pm .01 mVDC source to the TB 4 terminals 1 and 2. Be sure to observe the proper polarity when connecting the source. Terminal 1 is positive and terminal 2 is negative. Press the DOWN key, **deLy** will be displayed for 10 seconds and then **SCAn** for 10 seconds. When the calibration is complete **CAL 2** will reappear.

Error recovery:

See section 5.6 (page 60) for details. Insure that the millivolt source is connected correctly and functioning properly.

The calibration can be exited when **hLd1** or the calibration reference number is displayed by pressing the SCROLL key.

CAL2 QUICK CALIBRATION

This routine will allow the operator to execute a rough calibration on their unit via the keypad with no other equipment or disturbance to established wiring. It is intended to provide a partial recovery from a calibration corruption where the necessary equipment indicated may not be available. It should be noted that this is not intended as a substitution to the main calibration procedure described earlier and may deter considerably from the accuracy of the instrument.

With **CAL2** displayed, press and hold the DOWN ARROW key, then press the SCROLL key. Release both keys and the instrument will display **hLd1**. Press and hold the UP ARROW key, then press the SCROLL key. The display will momentarily blank and then **CAL1** will be displayed. Release both keys and depress the UP ARROW key. **CAL** will be displayed.

5.4.3 CAL 3 COLD JUNCTION COMPENSATION

This routine determines and saves calibration values which correct for component variations relating to the cold junction compensation. This calibration must be preceded by **CAL 2** the main calibration, to properly calibrate the instrument. These two calibrations are all that is needed for proper operation with thermocouple inputs.

Test equipment: 1-type J thermocouple
1-mercury thermometer $\pm .25$ degrees F or equivalent

Allow 30 minutes of warm up time for the instrument with the thermocouple connected before proceeding with calibration.

Operation:

With **CAL 3** displayed press and hold the DOWN key, then press the SCROLL key . Release both keys and the instrument will display **hoLd**. Connect the J thermocouple to TB 4 terminals 1 and 2 and place the thermometer inside the case at the bottom of the instrument. Short the input terminals TB5, 1 and 2. Press the DOWN key, **deLy** will be displayed for about 10 seconds, then **SCAn** for 10 seconds. The display will be the temperature to the nearest tenth of a degree C. Compare the display reading with thermometer and use the UP and DOWN keys to correct the reading. To exit press the SCROLL key and **CAL 3** will be displayed again.

If the display stays in **SCAn** for more than 15-20 seconds, press the SCROLL key. CAL3 should be displayed. With CAL3 displayed, while pressing the DOWN key, press the SCROLL key. The instrument will display **hoLd**. Press the UP key. The instrument will begin the calibration procedure with a default calibration value and proceed to **dELy** as described .

Error recovery:

See section 5.6 (page 60) for details on specific errors. The calibration can be exited if **hoLd** or the CJC temperature is displayed by pressing the SCROLL Key.

5.4.4 CAL 4 COLD JUNCTION UTILITY

This procedure displays the temperature the cold junction compensator is sensing. No test equipment is required.

With **CAL 4** displayed press and hold the DOWN key, then press the SCROLL key . Release both keys and **SCAn** will be displayed for 10 seconds while the instrument senses the CJC temperature. The result will then be displayed to a tenth of a degree C. The input terminals must be shorted. **CAL 3** must first be performed. ***The displayed temperature is not the ambient temperature. It is the temperature of the CJC .*** To exit, press the SCROLL key and **CAL 4** will be displayed.

5.4.5 CAL 5 RTD INPUT

This procedure determines and saves calibration values relating to RTD inputs. This calibration must be preceded by **CAL 2** to properly calibrate the instrument. Both RTD inputs must be calibrated and both inputs must have valid inputs during the calibration. Decade resistance substitution box with .01% resolution or equivalent are required. **Make sure that the Processor board jumpers JU4, JU6 and JU5, JU7 are in the proper positions. See Appendix A-1 (page 68).**

With **CAL 5** displayed, press and hold the DOWN key and then press the SCROLL key. The display will now be **PEn1** to indicate that the instrument is set to calibrate the RTD input on TB 4. Press the DOWN key to change the display to **PEn2** to calibrate the RTD input at TB 5. Choose the input TB to be calibrated and press the SCROLL key, **hLd1** will then be displayed. Connect the decade box at 100 ohm setting across the input terminals 1 and 2 and a jumper wire from terminal 2 to 3. (Continued on next page)

Press the DOWN key and **dELy** will be displayed for 10 seconds, then **SCAn** for ten seconds. When **hLd2** is displayed, change the decade box setting to 138.5 ohms to the input terminals (do not disturb the wiring) and press the DOWN key. The display will change to **dELy** for 10 seconds, followed by **SCAn** for ten more seconds. **CAL 5** will be displayed after the calibration is completed.

Error recovery:

See section 5.6 (page 60) for details on specific errors.

The calibration can be exited when the instrument displays **hLd1** or **hLd2** by pressing the SCROLL key.

5.4.6 CAL 6 COLD JUNCTION UTILITY

This routine provides selection of operating modes for the cold junction compensation used for thermocouple inputs.

With **CAL 6** displayed, press and hold the DOWN key, then press the SCROLL key. The instrument will display **C6** and the number of the mode in effect. Press the UP or DOWN key to change the mode selection indicated by the number to the right of the C6. Pressing the SCROLL key will exit the calibration with the last mode number displayed in effect.

The selected mode will remain in effect if power is interrupted. To return the instrument to normal operation, **CAL 6** must be exited, with mode zero selected, or **CAL 1** must be executed to initialize all parameters.

Mode 0: Normal operating mode.

Mode 1: Cold Junction Compensation temperature will be internally fixed at 0 degrees C by the software to facilitate linearization testing when using an uncompensated millivolt source to simulate the thermocouple millivolt input signal.

This calibration mode is only available on dual pen instruments.

Mode 2: Select Mode 2. Exit the Calibration Mode. Enter setpoint (SP) values for Pen 1 and for Pen 2. The SP for Pen 1 is used as the dry-bulb temperature and the SP for Pen 2 is used as the wet-bulb temperature. Enter Setpoints (dry-bulb and wet-bulb temperatures) for a known Relative Humidity value. Pen 1 or Pen 2 must also be preselected for Relative Humidity-PEnS=3. Check the display for the pen with PEnS=3 for the Relative Humidity percentage based on Setpoint selections of Pen 1 and Pen 2. After viewing the Relative Humidity percentage, enter the Calibration Mode, CAL 6, and select 0 (normal mode) for the mode selection. Exit the Calibration Mode and return the instrument to the desired mode of operation. This is a validation of the accuracy of the instrument's algorithm and Pen 1 and Pen 2 accuracy where whole numbers are used. The instrument will not control properly while in this mode.

Note: If the Process Value exceeds 999.9, the leftmost digit will be the letter o with a bar over it. The other digits will be valid.

WARNING: It is highly recommended to disconnect all outputs before selecting Mode 2 of CAL 6 as the instrument will not control properly.

If the mode value can only be set to 0 or 1, only the normal and CJC Temp= 0 are available. This change applies to newer software which includes normal operation to a tenth of a degree.

5.4.7 CAL 8 PROFILE REINITIALIZATION

This procedure is used to erase all profiles that have been entered in the instrument. Be sure to record any profile information on the Profile Recording Sheets (Appendix F, page 83) that will need to be re-entered after performing this procedure

With **CAL 8** displayed, press and hold the DOWN key , then press the SCROLL key. The display will blank momentarily and then **CAL 8** will be displayed.

5.4.8 CAL 9 PEN CALIBRATION

This procedure is used to calibrate the pen(s). No special test equipment required.

Valid inputs must be connected to TB 4 and TB 5 before performing this calibration. With **CAL 9** displayed, push and hold the DOWN key, then press the SCROLL key . Release both keys and the display will indicate **PEn1**. For 2 Pen instruments, press the DOWN key to toggle the display between pen 1 and pen 2. With desired pen displayed, press the SCROLL key.

FOR INSTRUMENTS WITH SOFTWARE REVISION R2.99 AND BELOW:

dELY will be displayed as the pen selected moves toward the center chart hub. **PEnL** will be displayed; use the UP and/or DOWN keys to adjust the pen to the low end or 0% of the chart. When adjusted, press the SCROLL key, **SCAn** will appear for 10 seconds and the pen location value will be saved in memory. Next **dELY** will appear as the pen moves to the outer edge or, 100% mark on the chart. **PEnh** will appear, use the UP and/or DOWN keys to adjust the pen position to the proper 100% of chart position. Press the SCROLL key and **SCAn** will be displayed as the pen position value is saved. Then **dELy** will be displayed as the pen moves to about mid-scale. **CAL9** will be displayed showing that the calibration is complete. When the calibration is complete, with **CAL9** displayed, press the UP key twice to properly exit the calibration mode. **CAL9** can now be repeated on the other pen of a 2 pen instrument or another routine can be selected.

FOR INSTRUMENT WITH SOFTWARE REVISION R3.00 AND ABOVE:

P.dn will be displayed while the selected pen is moved to it's "HOME" position (toward the chart hub) with the decimal point flashing to indicate this mode. Once "Pen Home" is found, the pen will move to the inner ring and **PEnL** will be displayed. At this point, one of two adjustments may be made; Pen Arc or Zero and Span.

Pen Arc - To adjust the pen arc, the UP and DOWN keys are pressed simultaneously to draw an arc for visual reference. The display will show **P uP** while the selected pen moved upscale to the top stop position. The pen then moves back downscale to nominally place the pen at the outer ring (100%) of the chart. The display will now display **ArC**. The pen arm may be loosened and the length adjusted to a position and angle to place the pen tip near the outer ring then re-tighten the pen arm. Press any key and the pen will drive to "HOME", then back to the inner ring (0%) and **PEnL** will be displayed.

Zero and Span - To begin a pen zero, with **PEnL** in the display, the UP or DOWN key may be pressed to move the pen to the low end of the chart span (0%). When adjusted, press the SCROLL key and **P uP** is displayed while the pen is moved to the outer edge (100%) of the chart, then **PEnh** is displayed. To adjust pen span, use the UP and DOWN keys to adjust the pen for the high end (100%) of the chart. When adjusted, press the SCROLL key and **P dn** will be displayed for about 5 seconds while the pen is moved to the 50% point on the chart, then **PEn1** is displayed. Calibration may now be performed again to verify the accuracy, or press the UP key twice to exit back to the CAL mode.

Test Mode Procedures 5.5

To enter the Test mode, press and release the SCROLL key until **tESt** appears on the display then press the DOWN key. **tSt1** will be displayed, press and release the SCROLL key to advance the display to the desired test. Tests 1, 2 and 3 are performed as a unit so the display will advance directly to **tSt4** from **tSt1**. Listed below in Table 5-2 are the test procedures available. Test 1, 2 and 3 are performed on start up, periodically during operation, and on entry into the Test mode. Test 4 is executed on entry into and periodically during the Control mode. These tests can be used as a trouble shooting aid.

TEST MODE FLOW CHART

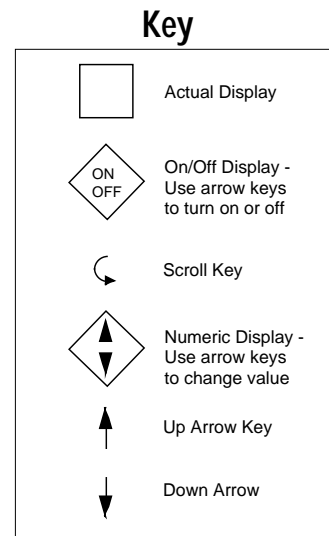
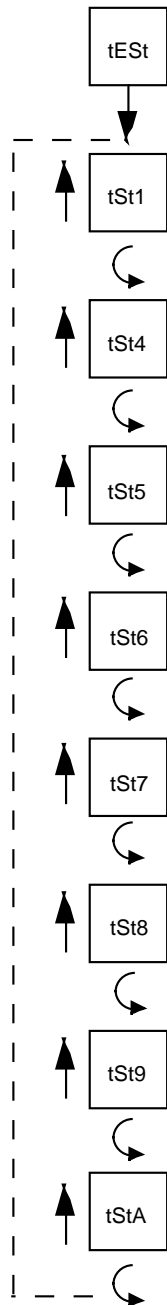

TABLE 5-2 TEST PROCEDURES AND DESCRIPTION

<u>Test</u>	<u>Description</u>
Test 1	Microprocessor internal RAM test. Used to check the processor RAM to make sure it is functioning correctly.
Test 2	External RAM test, used to test the RAM chip for proper function.
Test 3	EPROM checksum test, used to check that the EPROM program is correct.
Test 4	External RAM checksum test; instrument test and identifies how many times Errors 16, 17 and 18 have occurred.
Test 5	Verifies that all keys are functional and all LEDs are working.
Test 6	Used to verify that all relays and solid state relay driver outputs are working correctly.
Test 7	This procedure will allow operator to adjust the current output value to check the output and to test the operation of the external device.
Test 8	Pen and chart motor operational check.
Test 9	Auxiliary Input Test. Allows for the viewing of the optional auxiliary input voltage level and the pen motor position feedback signal.
Test A	Communications Hardware Test.

5.5.1 TEST 1 INTERNAL RAM TEST

Tests the Random Access Memory internal to the microprocessor. No special test equipment is required.

With **tSt1** displayed, press and hold the DOWN key, then press the SCROLL key. **tSt1** will be displayed momentarily while the test is in progress. Upon successful completion, the instrument will proceed to Test 2.

5.5.2 TEST 2 EXTERNAL RAM TEST

Tests the battery backed-up RAM external to the microcomputer. No special test equipment is required.

After completion of Test 1, **tSt2** will be displayed momentarily while the test is in progress. Upon successful completion, the instrument will proceed to Test 3.

5.5.3 TEST 3 PROGRAM EPROM TEST

This is a checksum test to verify data integrity of the stored program. No special test equipment is required.

After completion of Test 2, **tSt3** will be displayed momentarily while the test is in progress. Upon successful completion of Test 3 **tst1** will be displayed.

5.5.4 TEST 4 EXTERNAL RAM CHECKSUM TEST

This is a checksum test to verify the integrity of data stored in RAM and indicate the number of times the instrument has had an Error 16 or 17. The unit may have automatically recovered from these errors. No special test equipment is required.

With **tst4** displayed, press and hold the DOWN key then press the SCROLL key. The display will blank momentarily, then momentarily display two numbers, and then **tst4** will be displayed. These numbers indicate the number of times Error 16 and 17 have occurred respectively. Test 4 can be executed again, or another test may be selected.

5.5.5 TEST 5 KEYPAD/DISPLAY TEST

This test allows the operator to verify that the keys work and that all display elements can be lighted. No special test equipment is required.

With **tSt5** displayed press and hold the DOWN key, then press the SCROLL key and then release both keys. The display will go blank. The following code will be displayed while the corresponding key is pressed:

Key	Display
SCROLL	SCrL
UP	uAro
DOWN	dAro
AUTO/MAN (Pen 1)	Autu
RUN/HOLD	run
AUTO/MAN (Pen 2)	AutL
UP and DOWN	(All LED's and segments lit)
SCROLL and UP	(exit)

To exit, press the SCROLL and UP keys simultaneously, **tSt5** will be displayed.

5.5.6 TEST 6 RELAY/ SOLID STATE RELAY DRIVER OUTPUT TEST

Allows the operator to verify that the Relay and /or the Solid State Relay Driver output(s) are working. A volt/ohm meter will be required to test the output.

With **tSt6** displayed, press and hold the DOWN key, then press the SCROLL key. **oFF** will be displayed. For SPST Relay outputs, connect the meter across the relay output in the ohm scale. For SPDT Relay outputs, connect the meter across the N.O. and COM output in the ohm scale. The meter should read continuity with the relay on and infinity when the relay is off. For SSR Driver outputs, connect the meter across the output in the Volt DC scale. The meter should read 5 VDC when the SSR driver is on and 0 VDC when the driver is off. Press and release the DOWN key to advance through the following sequence:

DISPLAY	RELAY ON SPST	RELAY ON SPDT
rLYA	A	A
rLYb	B	B
rLYC	C	C
rLYd	D	D
rLYE	E	None
rLYF	F	None
rLYg	G	G
rLYH	H	H
oFF	None	None

To exit, press the SCROLL key and **tSt6** will be displayed. **The existence of Relay and Solid State Relay Driver output(s) is dependent upon the hardware configuration.**

5.5.7 TEST 7 CURRENT OUTPUT TEST

This test allows the operator to verify that the current output(s) are functioning properly or will allow the selection of an output value for testing of associated equipment. A milliamp meter is required for testing.

With **tSt7** displayed press and hold the DOWN key, then press the SCROLL key. The display will indicate **CurA**, for the first current output. By pressing the DOWN key, the instrument will advance through the selection sequence of **Curb**, **CurC**, **Curd**, and then back to **CurA**. Choose the desired output to be tested and connect the milliamp meter across the output terminals being tested. Be sure to observe the proper polarity when connecting the meter. Terminal 1 is positive and terminal 2 is negative. Press the SCROLL key and the display will indicate 4 milliamps. Use the UP and/or DOWN key to increase or decrease the current output in 1 mADC steps from 0 to 20 mADC. The current output reading should be +/- 0.1 mADC at any output value. An +/- 5 % of span adjustment for the current output(s) is provided by using the potentiometer adjacent to the current output on the Current Output board. See Appendix A-4 (page 83) .

To exit the test, press the SCROLL key and **tSt7** will be displayed. **The existence of a mAADC current output is dependent upon the hardware configuration.**

5.5.8 TEST 8 PEN/CHART MOTOR TEST

This test allows the operator to verify that pen and chart motors are functioning properly. No special test equipment is required.

With **tSt8** displayed press and hold the DOWN key, then press the SCROLL key. The display will show **ALL** while the test is in progress. This test functions automatically. The chart speed will be at maximum, approximately 80 seconds per revolution. Starting at the current pen position, pen 1 will move (sweep) upscale for 2 seconds, then downscale for 2 seconds. Pen 2 (if provided) will sweep in the opposite direction. The pens will continue to cycle until the test is exited. To exit, press the SCROLL key. The display will show **tSt8**.

5.5.9 TEST 9 AUXILARY INPUT TEST

This test allows the operator to verify that the auxiliary input(s), if specified, pen position feedback input(s) are functioning properly.

Auxiliary inputs are the remote setpoint and position proportioning options. With **tSt9** displayed, press and hold the DOWN key, then press the SCROLL key. The display will show **Ai1**, Auxiliary Input 1. By pressing the DOWN key, the instrument will sequence through the selections for testing: **PF1**, **Ai2**, **PF2**, then back to **Ai1** (PF=Pen Feedback). With the desired input selected, press the SCROLL key. The corresponding value will be displayed. For software revision R2.99 and below only, the pen position feedback input voltage will be displayed to the nearest tenth of a millivolt. Manually move the pen up and down scale and verify that the displayed reading changes from about 0 to 50 millivolts. For software revision R3.00 and above, the pen position feedback input voltages are disabled and will display a fixed value of zero. To terminate a particular test, press the SCROLL key. The display will show **tSt9**.

5.5.10 TEST A COMMUNICATION HARDWARE TEST (Communications Option)

This test allows the operator to verify that the communications hardware is functioning properly.

With **tStA** displayed, press and hold the DOWN key then press the SCROLL key. The display will indicate **SEnd**. Press the DOWN key to toggle the display between **SEnd** and **rEC**. With the desired function selected, press the SCROLL key. In the **SEnd** (send or transmit) mode, the instrument will repeat the following sequence. First the transmitter will output a logic 1 on the line for one second. Next the transmitter will change the logic level to 0 for one second. Then the transmitter will disable for one second. In the **rEC** (receive) mode, the transmitter is continuously disabled. In either mode, the instrument will monitor the line and display **rEC1** when a logic 1 is on the line or **rEC0** when a logic 0 is on the line. In the **SEnd** mode, the instrument will display **rEC** when the transmitter is disabled. To perform an internal test and verify the basic operation of the hardware, place the instrument in the Send mode and verify that the display cycles through **rEC1**, **rEC0**, and **rEC**. To verify that the transmitter functions properly, two LED's, each with a current limiting resistor, can be connected with opposite polarity observed to the TB 2 terminals 1 and 2. The following three states should be observed: one LED on, then the other LED on, then both off. Alternately, a load resistor can be placed on the terminals, and observe that the voltage generated across the load resistor is as follows: > +3 VDC, then < -3 VDC, and then 0 VDC.

Another method, to test the communications hardware, would be to connect one or more instruments in the Receive mode to an instrument in the Send mode. All of the instruments in the Receive mode should have their displays alternating in sync with the instrument in the Send mode. When the sending instrument displays **rEC**, the receiving instruments should display **rEC1**. To terminate the test, press the SCROLL key for one second. Upon exit, **tStA** will be displayed. **The existence of the communications hardware is dependent on the hardware configuration.**

Trouble-shooting and Diagnostics 5.6

The Trouble-shooting Guidelines Section consists of two columns. The first column is a list of some possible instrument conditions. The second column is a list of steps that should improve the condition. The steps should be performed in order until the condition improves or all the steps have been completed. If the instrument condition has not improved contact the nearest Partlow representative or the factory for assistance.

Trouble-shooting should be performed by qualified personnel using the proper equipment and following all safety precautions. Whenever possible the trouble-shooting should be accomplished with the electrical power disconnected. The instrument contains static sensitive components so care should be taken to observe anti-static procedures.

Condition

Correction Steps

Display(s) is/are blank

1. Verify that the correct instrument power, as indicated on the wiring label on the platen, is supplied to TB 1 terminals 1 & 2. Check the position of the power select switch, on 230 VAC models, correctly indicates the power that is connected to the instrument. If the switch does not indicate the correct voltage reposition as necessary. If the voltage is not correct check the power source.
2. Turn off the instrument power. Wait about 5 seconds then turn the power on again.
3. Turn off the instrument power, open the cover, loosen the platen hold down screw, and swing the platen out of the way. Inspect the instrument for poor connections.
 - a. The white ribbon cables that connect the Processor board (Appendix A-1, page 68) to the platen must be properly aligned and seated in the sockets.
 - b. The display board(s) white ribbon cable(s) pins should be properly aligned and seated in the sockets on the platen potentiometer segment board.
 - c. Inspect the PROM, RAM and microprocessor chips to see if they are properly seated in their sockets (Appendix A-1, page 68).
 - d. Close the platen and tighten the hold down screw. Close the cover and turn on the power to see if the display(s) will now light.
4. Turn off the instrument power. Press and hold the UP and DOWN keys. Turn on the power. Hold the keys pressed for about 10 seconds. If the display(s) light(s), the model number, Program and Tune mode parameters will need to be re-entered (page 30 and 37, or the Software Ref. Sheet, page 80, if already filled out).

Model Number Displayed during power up is incorrect (Re-initialization)

1. Turn off the instrument power, wait 5 seconds then re-apply the power. Verify that the number displayed during the power up sequence is the same as indicated on the label affixed to the platen. If the number displayed is incorrect perform the following steps:
 - a. Turn off the power to the instrument. Press and hold the UP and DOWN keys. Turn on the power and keep the keys pressed until the model number displayed resets to 77X0-0000-0000. Release the keys and turn off the power.
 - b. To enter the correct model number press and hold the SCROLL and DOWN keys and turn on the instrument power. **77X0** should be displayed. Wait about 5 seconds and release the keys. The display should stay **77X0**. Use the UP/DOWN keys as necessary to change the displayed number to match the first 4 digits of the model number as indicated on the label on the platen. After adjusting the first 4 digits to the proper values, press the SCROLL key and the display will change to be **0000**. Use the UP/DOWN keys to set the next 4 digits of the model number to the correct values. Press the Scroll key and the display will be **0X21**. Use the UP/DOWN keys as necessary to adjust the last 4 digits of the number. Press the SCROLL key and the power up sequence will complete. The Program and Tune mode parameters will need to be re-entered (page 30 and 37), or the Software Ref. Sheet, page 80, if already filled out).

Relay/SSR Driver malfunction

1. Verify that the Program and Tune mode parameters are correctly set (page 30 and 37, or the Software Ref. Sheet, page 80, if already filled out).
2. Turn off the power to the instrument. Wait about 5 seconds and turn the power on again. Confirm that the model number displayed during the power up sequence indicates that the output(s) is/are present in the instrument. See Appendix C (page 75) for the model number explanation/decoding. This number should match the number on the label affixed to the platen.
3. Turn off the power to the instrument. Open the cover. Loosen the platen hold down screw and swing the platen open. Inspect the instrument Relay/SSR Driver board (See Fig. 2-4, page 14) for the presence of the output device(s). An output relay will appear to be a cube. The SSR Driver will appear as a resistor and a jumper wire. The output will not work if the hardware is not present. Inspect that the output terminal connections are present and firmly attached.

4. Check the output(s) operation by performing Test 6 as described in the Test section. If the output(s) function in the Test mode, check the Program and Tune mode parameters to see if correctly selected (see page 30 & 37 or the Software Ref. Sheet, page 75, if already filled out).
5. If the output appears not to turn off remove the power to the instrument. Open the cover and loosen the platen hold down screw. Swing the platen open. Clip the resistor located on the Relay Board adjacent to the output(s) that seem to stay on (See Appendix A-2, A-3 page 69, 70). A .01 microfarad, 1 KV should be connected from the terminal listed below, for the output where the resistor indicated was removed, to the AC ground.

Relay A	R1	TB 6	Terminal 1
Relay B	R2	TB 6	Terminal 3
Relay C	R3	TB 7	Terminal 1
Relay D	R4	TB 7	Terminal 3
Relay E	R5	TB 8	Terminal 1
Relay F	R6	TB 8	Terminal 3

Close the platen and tighten the hold down screw. Close the cover and turn the power on to the instrument. Check the operation of the output(s).

**mADC Output(s)
malfunction**

1. Verify that the Program mode parameters are correctly set (page 30 or the Software Ref. Sheet, page 80, if already filled out).
2. Turn Off the power to the instrument. Wait about 5 seconds and turn the power on again. Confirm that the model number displayed during the power up sequence indicates that the output(s) is/are present in the instrument. See Appendix C (page 75) for the model number explanation/decoding. This number should match the number on the label affixed to the platen.
3. Turn off the power to the instrument. Open the cover. Loosen the platen hold down screw and swing the platen open. Inspect the instrument Current Output board (See Fig. 2-4, page 14) for the presence of the output device(s). The output will not work if the hardware is not present. Inspect that the output terminal connections are present and firmly attached. Close the platen and tighten the hold down screw. Close the cover and turn on the power.
4. Refer to the Test section and carry out the procedure for the Current Output(s) Test 7 (page 58). If the current output operates properly in the Test mode recheck the Program mode parameters (page 30, or the Software Ref. Sheet, page 80, if already filled out).

Pen(s) do not operate

1. Verify that the Program mode parameters are properly set (page 30 or the Software Ref. Sheet, page 80, if already filled out).
2. If the process value in the display exceeds the chart upper or the chart lower values selected in the Program mode the pen will appear stuck at the chart upper or lower edge respectively. Reconfigure values as needed by the application (May require a new chart).
3. Perform Test 8 as described in the Test section of the manual (page 59) . If the pen(s) operate in Test 8, perform the pen calibration, Cal 9, as described in the Calibration section of the manual (page 55). Return the instrument to the **oPEr** and check the operation of the pen(s).
4. For software revision R2.99 and below, perform Test 9 as described in the Test Section of the manual (page 59). If the pen feedback voltage does not vary, check the pen Potentiometer Segment board for proper ribbon cable connection to the Processor board (Appendix A-1, page 67) and that the pen position fingers are making contact with Potentiometer Segment board.
5. For software revision R2.99 and below, inspect to see that the Potentiometer Segment of the pen feed back is clean. Use a non-residue type cleaner that does not affect the plastic to clean the segment if necessary.
6. Verify the instrument is not in Change Chart function.

*Note: Since the 7700 is available as a one pen unit with one display, even though it always has two inputs, the error routine has been changed. Any error, in particular pen or input related errors, will always be displayed in the upper display. The second display, if present, will be blanked. Therefore, a sensor break on either input will be identified by a **SnSr** message in the upper display and outputs for both pens to to the error condition.*

Error Code Displayed

SnSr - Sensor Break or Over Range

1. Inspect the sensor for proper operation and connection to the instrument. Acceptable sensor ranges for the instrument are listed in the Specifications section of the Appendix D (page 76).
2. Verify that the Program mode input selection matches the sensor input connected.
3. Check that the input conditioning jumpers on the Processor board(Appendix A-1, page 68) are in the proper position for the sensor input. Check that the jumpers are in the proper position for the Terminal Board where the sensor is connected.
4. Perform the calibration procedure(s), as described in the Calibration section, for the sensor input type.

Hi - Input more than 10% Over Span

1. Perform the steps listed for the **SnSr** Error Condition.

Lo - Input more than 10% Under Span

1. Perform the steps listed for the **SnSr** Error Condition.

FbEr Slidewire Feedback Error	<ol style="list-style-type: none">1. Inspect the Slidewire Feedback connections at terminals 8, 7 and 5. Be sure that the connections are the same as shown in the position proportioning illustration (page 20).2. Measure the resistance of the Slidewire segment. The minimum resistance must be 135 ohms, the maximum 10 K ohms.3. Perform the Auxiliary Input Test, Test 9 as described in the Test section (page 59). The voltage indicated should be between 0 and 5 VDC.
rSEr - Remote Setpoint Error	<ol style="list-style-type: none">1. Check the Program mode (page 30) to see that the correct remote setpoint voltage has been selected.2. Check the voltage at the remote setpoint terminals 3 and 5 for the proper voltage.
6̄ - display overranged (the "broken 6" appears on the left segment of the display)	<ol style="list-style-type: none">1. If this error code is displayed as a Program or Tune mode parameter perform the Cal 1 procedure as described in the Calibration section of the manual (page 52).2. If this error code appears as part of the model number during the power up sequence follow the steps listed for when the "Model Number is not correct" condition (page 61).
Er 1 - Microprocessor RAM Failure	<ol style="list-style-type: none">1. Turn off the power to the instrument. Wait 5 seconds, and turn the power on.2. Turn off the power to the instrument. Open the cover, and loosen the platen hold down screw. Swing open the platen and inspect that the microprocessor chip (U5) is properly seated in the socket located on the Processor board (Appendix A-1, page 68). Close the platen and tighten the screw. Close the cover and turn on the power.
Er 2 - External RAM Failure	<ol style="list-style-type: none">1. Turn off the power to the instrument. Wait 5 seconds, and turn the power on.
Er 3 - PROM Checksum Failure	<ol style="list-style-type: none">1. Perform the steps listed for Er 1 except that the PROM (U7) on the Processor board (Appendix A-1, page 68) should be inspected.
Er 4 - RTD Mismatch Error	<ol style="list-style-type: none">1. Check the connections to the instrument for the RTD Input Calibration (CAL5) are as described in the Calibration section (page 54). Repeat the RTD Input Calibration.

Er 5 - No Zero Crossings Detected	<ol style="list-style-type: none">1. Turn off the power to the instrument. Wait 5 seconds, and turn the power on.2. Connect the instrument to another AC power source.
<hr/>	
Er 6 - AC line below 45 HZ	<ol style="list-style-type: none">1. Turn off the power to the instrument. Wait 5 seconds, and turn the power on.2. Connect the instrument to another AC power source.
<hr/>	
Er 7 - AC line over 65 HZ	<ol style="list-style-type: none">1. Turn off the power to the instrument. Wait 5 seconds, and turn the power on.2. Connect the instrument to another AC power source.
<hr/>	
Er 8 - Cal 2 Volt Input Error	<ol style="list-style-type: none">1. Check that 12.4 mVDC is properly connected to the instrument and is within the tolerance limits as indicated in the CAL2 procedure of the Calibration section (page 52).2. Turn off the power to the instrument and open the cover. Loosen the platen hold down screw and swing the platen open. Inspect the Processor board (Appendix A-1, page 68) to insure that the input conditioning jumper JU4 is in the non-volt position. The jumper must be in the non-volt position to perform the Calibration 2 procedure. Close the platen and tighten the hold down screw. Close the cover and turn on the power to the instrument.3. Perform the CAL2 procedure as described in the Calibration section (page 52).
<hr/>	
Er 9 - ADC Reference Number Error	<ol style="list-style-type: none">1. Perform the CAL2 procedure as described in the Calibration section (page 52).
<hr/>	
Er10 - ADC Reference Voltage Error	<ol style="list-style-type: none">1. Perform the CAL2 procedure as described in the Calibration section (page 52).
<hr/>	
Er11 - Cold Junction Compensation Error	<ol style="list-style-type: none">1. Perform the CAL3 procedure as described in the Calibration section (page 53).
<hr/>	
Er12 - CAL2 Voltage Error	<ol style="list-style-type: none">1. Check that 12.4 mVDC is properly connected to the instrument and is within the tolerance limits as indicated in the CAL2 procedure of the Calibration section (page 52).

2. Turn off the power to the instrument and open the cover. Loosen the platen hold down screw and swing the platen open. Inspect the Processor board (Appendix A-1, page 68) to insure that the input conditioning jumper JU4 is in the non-volt position.
3. Perform the CAL2 procedure as described in the Calibration section (page 52).

Er13 - RTD CAL5 Input Error

1. Check that the resistance device is of the correct value and properly connected to the instrument and is within the tolerance limits as indicated in the CAL5 procedure of the Calibration section (page 54).
2. Turn off the power to the instrument and open the cover. Loosen the platen hold down screw and swing the platen open. Inspect the Processor board (Appendix A-1, page 68) to insure that the input conditioning jumpers are in the correct position for the RTD input for the Terminal Board being calibrated. For TB 4, JU4 should be in the non-volt position and JU6 in the RTD position. For TB 5, JU5 should be in the non-volt position and JU7 in the RTD position.
3. Perform the CAL5 procedure as described in the Calibration section (page 54).

Er14 - Cold Junction Compensation Error

1. Perform the CAL3 procedure as described in the Calibration section (page 53).

Er15 - Ground Reference Tolerance Error

1. Perform the CAL2 procedure as described in the Calibration section (page 52).

Er16 - Program/Tune Mode Checksum Error

1. Record all Program and Tune mode parameters. perform the CAL 1 procedure as described in the Calibration section (page 52). Re-enter the Program and Tune mode parameters.

Er17 - Calibration Checksum Error

1. Perform the calibration procedures that are needed for the input sensors that will be used (page 51).
2. Perform a re-initialization (see Page 61).

Er18 - Profile Data Checksum Error

1. Record all Profile data that was entered. Perform the CAL 8 procedure as described in the Calibration section (page 55). Re-enter the Profile data as needed.

Er19 - Tried to run profile with 0 segments	<ol style="list-style-type: none">1. Press the RUN/Hold key, then press and release the SCROLL key until oFF or CtrlL are displayed then press the DOWN key. This error occurs if a profile number is selected in the Profile Continue mode for a profile that has not been developed.
Er20 - Setpoint Error	<ol style="list-style-type: none">1. Press the UP or DOWN key to change the setpoint to a different value, then restore the needed setpoint.2. Perform the CAL1 procedure as described in the Calibration section (page 52).
Er21 - Pen Feedback Error	<ol style="list-style-type: none">1. Perform the steps listed for "Pens do not operate" condition (page 63).
Er36 -Incorrect Crystal For Digital Comm.	<ol style="list-style-type: none">1. Turn off the power to the instrument, wait 5 seconds, then turn the power on.
Er37 - Incorrect Micro. For Digital Comm.	<ol style="list-style-type: none">1. Turn off the power to the instrument wait 5 seconds, then turn the power on.
Momentary Er70 - Controller unable to respond within 250 milliseconds	<ol style="list-style-type: none">1. Tried to communicate while unit was in a non-control mode.
Momentary Er71 - Byte received before the response was transmitted	<ol style="list-style-type: none">1. The unit received a request before proper amount of time has elapsed since last request.
Momentary Er72 - Incorrect Block check character received	<ol style="list-style-type: none">1. Data received not valid, possible corruption on the comm link. Possible noise.
Momentary Er73 - Byte received with incorrect parity	<ol style="list-style-type: none">1. Improper parity selection on the transmitting terminal.2. Incorrect baud rate.3. Noise.

Appendix A Board Layout

FIGURE A-1 - Processor Board

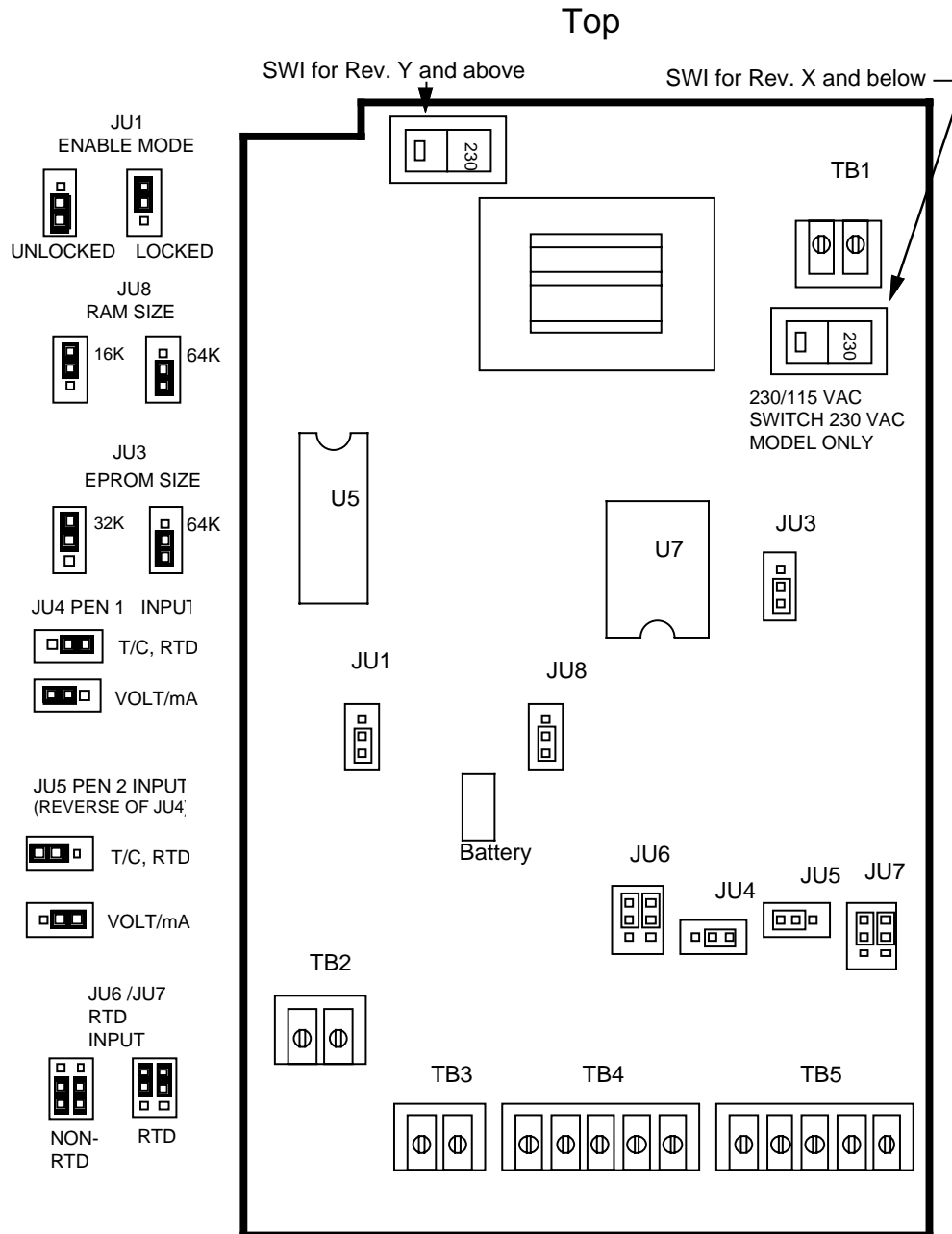
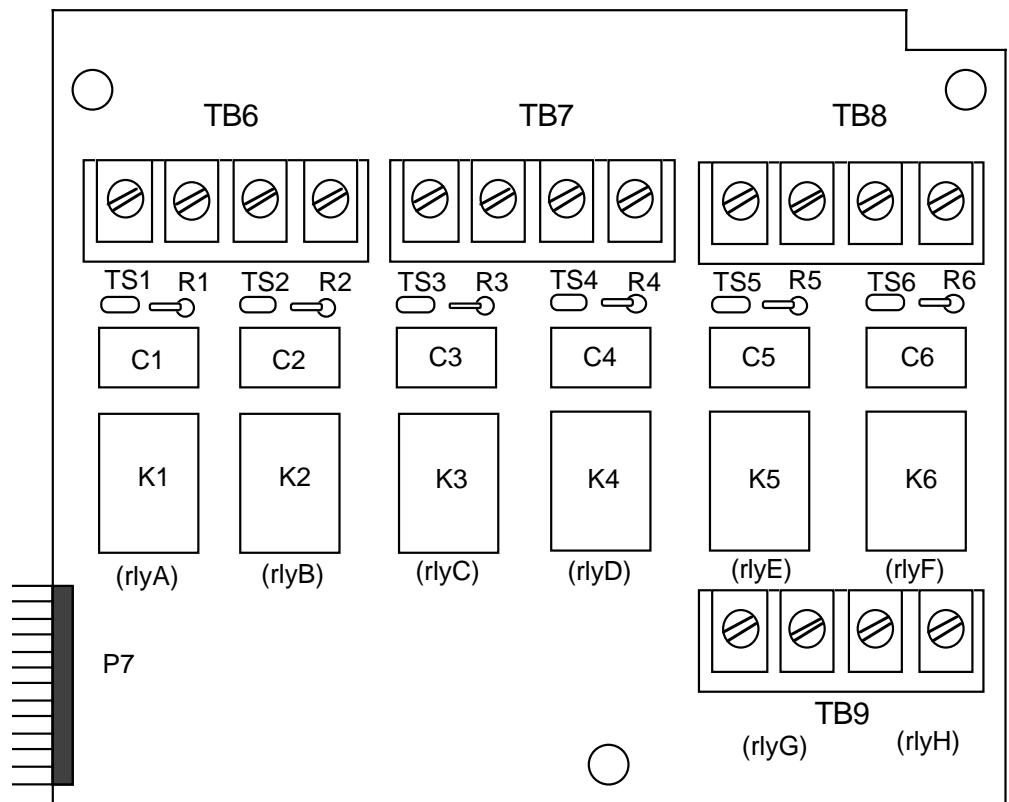

FIGURE A-2 - SPST Relay/SSR Driver Board



If the relay is connected to a high impedance AC device, the snubber network used to protect the relay contact may cause the output to appear to be activated when the relay is off. To cure the problem, cut the snubber resistor for the output that is being affected. Connect a .01 mf, 1KV capacitor from the odd numbered terminal to ground.

Resistor
 R1
 R2
 R3
 R4
 R5
 R6

Relay
 Relay A
 Relay B
 Relay C
 Relay D
 Relay E
 Relay F

FIGURE A-3 - SPDT Relay/SSR Driver Board

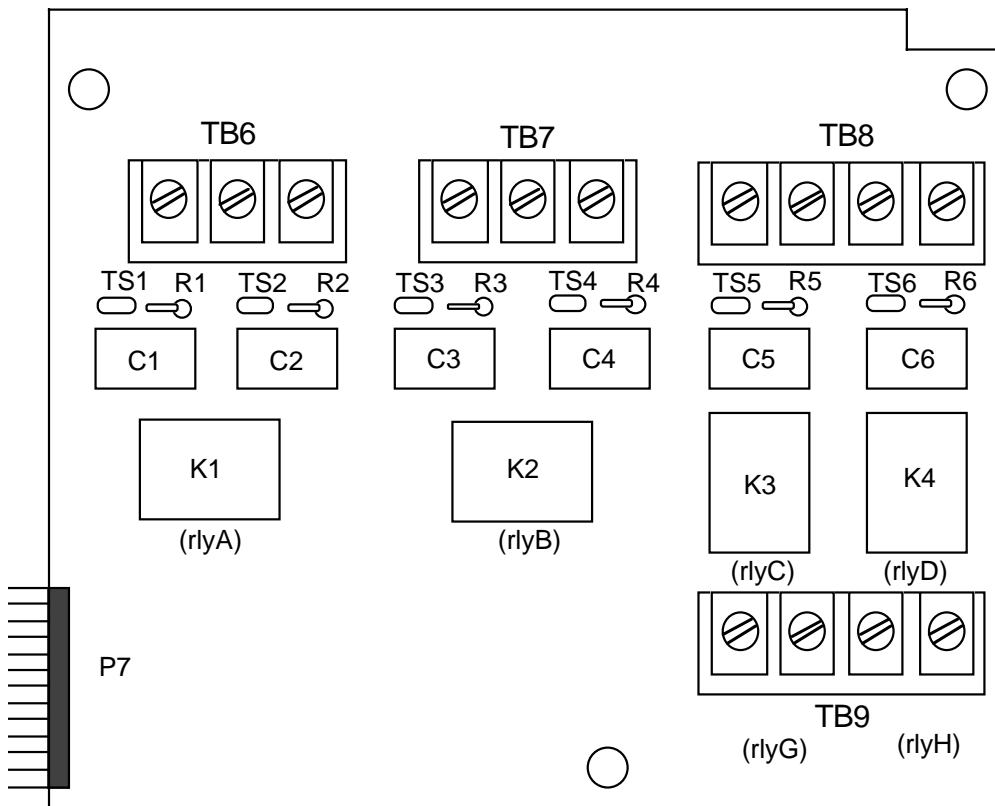

If the relay is connected to a high impedance AC device, the snubber network used to protect the relay contact may cause the output to appear to be activated when the relay is off. To cure the problem, cut the snubber resistor for the output that is being affected.

Resistor

- R1
- R2
- R3
- R4
- R5
- R6

Relay

- Relay A N.O.
- Relay A N.C.
- Relay B N.O.
- Relay B N.C.
- Relay C
- Relay D

FIGURE A-4 - Current Output Board

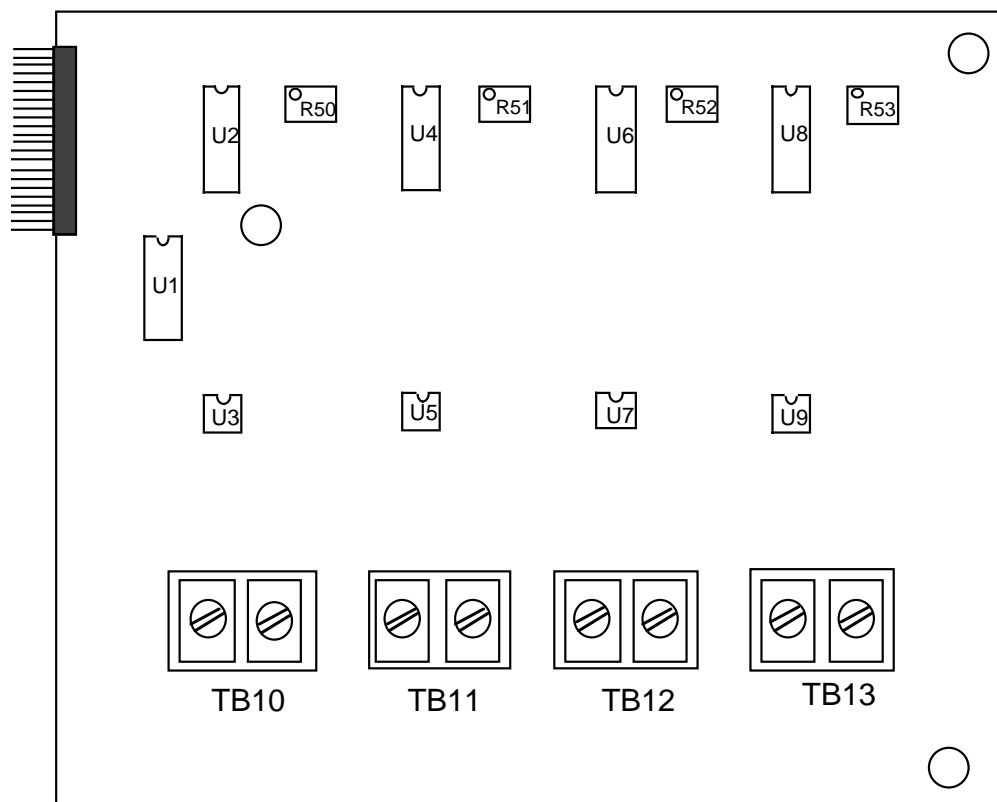

If this option board was ordered, you will find it located in the lower right hand corner of the instrument.

Appendix B

Glossary

Assured Soak

The instrument may be programmed to interrupt the Profile Soak segment if the process value exceeds a selectable deviation from setpoint value. The Profile will restart from where it was stopped when the process value does not exceed the deviation value selected from setpoint.

Automatic Reset (Integral)

This parameter is used so that the instrument will compensate for process variable deviations from setpoint that occur when the process load characteristics change. Instructions for determining the automatic reset settings are given in Section 4.3 (Page 47). Factory default is 0.0. Display code **ArS1** and **ArS2**.

Automatic Transfer

This feature, if configured, allows manual control of the process until setpoint is reached, at which point the controller automatically transfers from manual to automatic control. Factory default value is 0 = no auto transfer. Display code **AtFr**.

Bumpless Transfer

This feature prevents step changes in proportional outputs when changing from automatic to manual control only.

Cycle Time

This Tune mode parameter is used to select the on/off cycle time for time proportioning outputs (**Ct1** for Output 1 and/or **Ct2** for Output 2)

Display Filter Factor

This parameter is adjustable from 1 to 20 which represents the number of scans of the process variable that are averaged together before updating the displayed and recorded value. The factory default value is 1 = no filtering. Display code **dFF**.

Dry Bulb

Is the temperature sensor connected to TB4 that provides the ambient temperature input necessary for Relative Humidity calculations.

Engineering Units Upper and Engineering Units Lower

These Program mode parameters are used with volt and milliamp inputs. The Engineering Units Upper **EuU** should be selected as the value to be displayed when the input is at maximum. The Engineering Units Lower **EuL** should be selected as the value to be displayed when the input at at minimum.

First Output Position

This parameter is adjustable from -1000 to 1000 units and represents a shift or offset of the on-off actuation points or proportional band for the first output relative to the normal position. For example, a negative value could be used to offset an expected overshoot. First Output Position also shifts the proportional band with respect to the process value range outside of which integral action is inhibited. Factory default is 0. Display code **FoP**.

Hysteresis

This parameter is adjustable from 0 to 300 units representing the width of the band (half above and half below setpoint). Used with ON/OFF or Alarm outputs to reduce cycling. For instance, with a value of 4 and a setpoint of 70 the output will turn ON when the process variable drops to 68 and stay ON until 72 is reached, then turn OFF the output. Factory default = 3. Display code **HyAo** for Alarm outputs. Display code **HyCo** for ON/OFF Control Outputs.

Input Correction

This parameter is adjustable from -300 to 300 units and is used as a method to compensate for a linear sensor error. Factory default is 0 = no correction. Display code **iCi1** and **iCi2**.

Manual Reset

This parameter is adjustable from -1500 to 1500 units representing a manual shift of proportional band(s) relative to the normal position. Manual reset is intended to be used when automatic reset is not used to allow compensation for deviations from setpoint which remain after the process has stabilized. Factory default is 0. Increasing the value increases the process variable, i.e. if the process variable stabilizes too low, increase the manual reset value. Integral action, and conversely reset-windup inhibit apply over the same process value range regardless of the manual reset value. Display code **rSEt**.

Pen Action on Power Up

This parameter specifies whether the pen, on a power-up will drive to the "Home Position" (center of chart), then return to its correct position. This is done as a cal check. Settings are 0=go to "home" and 1=remain in last position prior to power down. Default is 0.

Platen

The flat surface in the instrument upon which the chart rotates.

Position Proportioning Sensitivity

A percentage of the first output proportional band width (**Pb1**).

Process Filter Factor

This parameter is adjustable from 1 to 20 which represents the number of scans of the process variable that are averaged together before updating the process value used for control purposes. The factory default value is 1 = no filtering. Display code **PFf**.

Process Retransmission Output

Allows re-transmission of the process variable. Factory default is 0 = not selected. Display code **Pout**. If selected, must be assigned to a current output and scaled using Process Output upper and lower values.

Process Output Upper and Lower Values

(Used in conjunction with process retransmission output)

These parameters specify the process value range over which the assigned current output will vary in a linear manner from 100% to 0%. If the process value is greater than **Pou** the output will be 100%. If the process value is less than **PoL** the output will be 0%. Factory default values are 2000 for the upper value and 0 for the lower value. Display codes **Pou** (upper) and **PoL** (lower).

Process Rounding

This parameter is adjustable from 0 to 100 units and is used to round the process value to the nearest value specified. This is for display only and does not affect the recorded value or control action. Intended for use where the engineering units span is large, to reduce display fluctuation. Factory default is 0 = no rounding. Display code **Prnd**. (e.g. Prnd = 3, Process Value = -6, -3, 0, 3, 6, 9....)

Proportional Band (PB)

This parameter is adjustable from 1 to 3000 units (not Percent of span) and represents the process value range where the proportional output is at a percentage of the full output. Instructions for determining Pb are given in Section 4.3. Factory default is 100 units. Display code **Pb1** and **Pb2**. Figures 1 and 2 in this appendix illustrate the position of the proportional band.

Ramp

A Ramp is the section of a profile segment where the setpoint value is being changed from the initial value to the value selected over the time period selected. The first Ramp of a profile will take the process value at the time the profile was started as the initial setpoint value.

Rate (Derivative)

This parameter is adjustable from 0.0 to 10.0 minutes and specifies how the control action responds to the rate of change in the process variable. For example, if the process variable is rising rapidly to setpoint, power is turned off sooner than it would be if the rise were slow. In effect, derivative action anticipates lags within the system and shifts the proportioning band by an amount determined by the rate of change of the input sensor.

Magnitude of the shift is determined by a derivative time constant. If the time constant is, say .1 minute (6 seconds), for every unit per second rate of change of the process variable at the sensor, the proportioning band is moved 7 units in the direction that helps control. Likewise, if the time constant is 1 minute (60 seconds), for every unit per second rate of change of the process variable at the sensor, the proportioning band is moved 60 units in the direction that helps control.

Instructions for determining rate are given in Section 4.3. Factory default is 0.0 Display code **rt1, rt2**.

Relative Humidity

Stated as a percentage, Relative Humidity is the ratio of water vapor that is present in the air to the maximum water vapor that the air can hold at the same temperature.

Second Output Position

This parameter is adjustable from -1000 to 1000 units and represents a shift or offset of the on-off actuation points or proportional band for the second output relative to the normal position. A positive value creates a gap where no control outputs are on, a negative value creates an overlap of control outputs (if the first output position is at the normal position). Second Output Position also shifts the proportional band with respect to the process value range outside of which integral action is highlighted (reset-windup inhibit). Factory default is 0. Display code **SoP**.

Segment

A segment refers to a part of a profile. A segment consists of a Ramp and a Soak section.

Soak

A Soak is the section of a profile segment where the setpoint value is at a constant value for the time period selected.

Wet Bulb

Is the temperature sensor that is kept moist (damp) and is connected to TB 5. This input is necessary for Relative Humidity calculations.

Appendix C Order Matrix

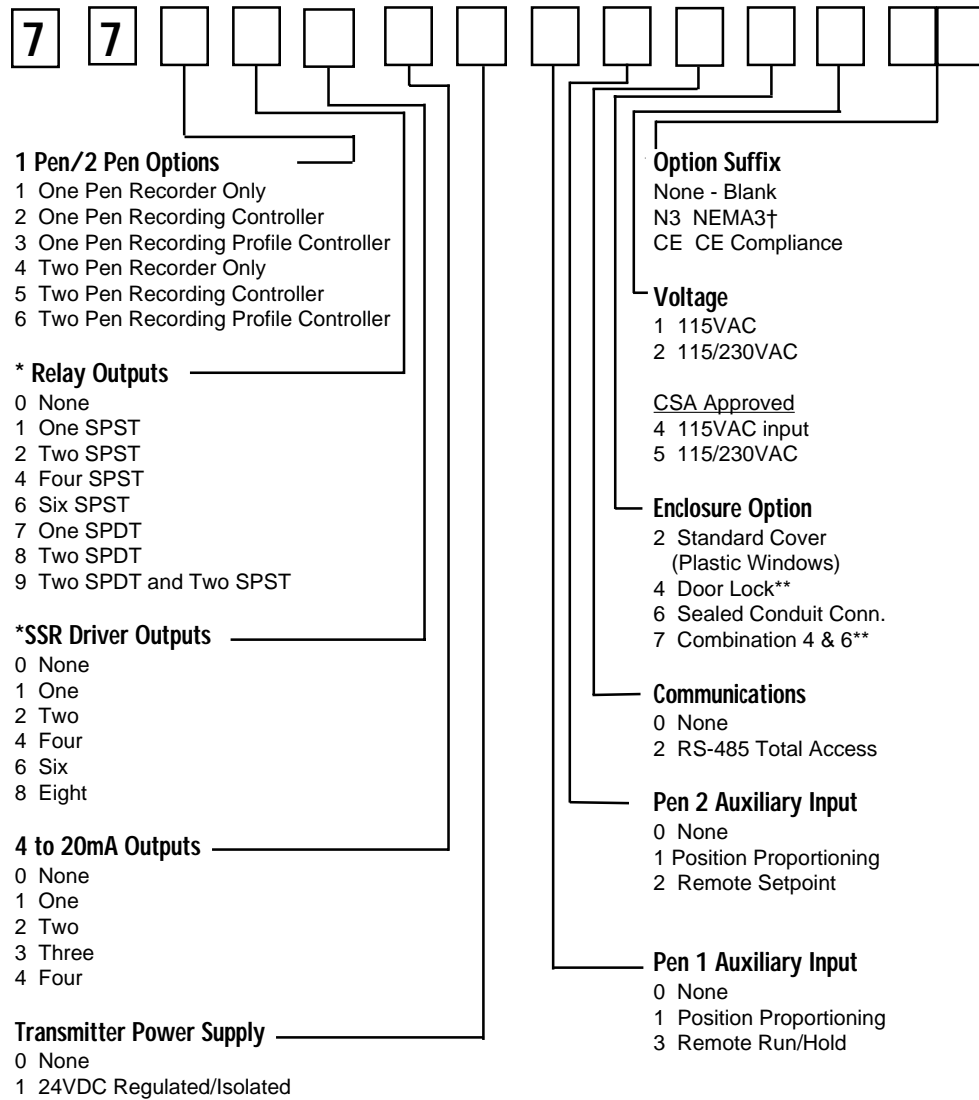

*Total quantity of SPST Relays and SSR Drivers must be less than or equal to (8) eight. When SPDT Relays are included, the total must be less than or equal to (6) six.

** This option comes with a structural foam cover.

† N3 - NEMA3 Equivalent Spray Resistant Enclosure.

Note: 4-20mA inputs are accommodated using the 1-5V input and a 250 ohm Shunt Resistor.

Appendix D Product Specifications

Measurement Error Limit	<ul style="list-style-type: none">• Type J,K,T,E,N,C T/C's and RTD +/- 0.25% of reading plus 1 degree @ 25 degrees C• Type R,S, B T/C's +/- 0.25% of span @ 25 degrees C• mA andVDC +/- 0.25% of scaled span plus 1 Whole Digit @ 25 degrees C
Ambient Temperature Error	0.01% of span per degree C deviation from 25 degrees C
Scan Rate	1 scan/second
Display Decimal Positions	One, two or three decimal places (0.1 or 1 degrees for T/C or RTD)
Noise Rejection	Normal mode, 85 dB minimum at 60 Hz or greater. Common mode, 90 dB minimum, 115 VAC maximum.
Line Voltage	115/230 VAC +/-10% 50/60 Hz
Power Consumption	25 VA maximum
Operating Temperature	32 degrees to 131 degrees F 0 degrees to 55 degrees C (ambient)
Storage Temperature	-40 degrees to 149 degrees F -40 degrees to 65 degrees C
Humidity	0 to 90% RH, non-condensing
Dimensions	13.19"H x 15.13"W x 3.63" Deep
Weight	20 pounds maximum
Sensor Fault Detection	Displays SnSr for sensor or transmitter break. Outputs go off. PV Out to 100%, Events status remains same. Fault detection is not functional for 0-5V or 0-20mA inputs
Agency Approvals	UL and CSA
EMI Susceptibility	Designed to meet EN 50082-2:1992

EMI Emissions	Designed to meet EN 50081:1994
Safety Considerations	Designed to comply with IEC 1010-1 in as far as it is applicable
Transmitter Power Supply	Provides up to 40mA of current at 24 VDC
Relative Humidity	Based on 100 OHM RTD (.00385 OHMS/OHM/degrees C) input, the Relative Humidity Accuracy is +/- 2% RH @ 25 degrees C and +/- 3% RH @ 5 to 50 degrees C range. Below 0.5°C/33°F Wet bulb sensed temperature, the RH value will be set to 100%.
Algorithm Accuracy	Actual user accuracy will be dependent upon the quality of the sensors used, the proper installation of the sensors, the input correction adjustments, and the barometric pressure adjustments.
Warranty	3 years, see back cover for details.

Input Specifications

THERMOCOUPLE

TYPE	RANGE	TYPE	RANGE
J	0 to 270C 0 to 520 F	E	0 to 215C 0 to 420F
K	0 to 360C 0 to 680F	B	200 to 1800C 400 to 3300F
T	-220 to 300C -330 to 570F	N	0 to 450C 0 to 842F
R	200 to 1300C 400 to 2370F	C	200 to 810C 390 to 1490F
S	200 to 1425C 400 to 2600F		

MILLIAMPS
4-20 MADC
(with resistor)

RTD
100 OHM
(.00385 OHMS/OHM/C)
-70 to 150°C, -94 to 300°F

VOLTS
0 to 5 VDC
1 to 5 VDC

REMOTE RUN/HOLD
Dry Contact Closure

REMOTE SETPOINT
0 to 5 VDC
1 to 5 VDC

CONTROL ADJUSTMENTS

Proportional Band	1 to 3000 units
Manual Reset	-1500 to 1500 units
Auto Reset (Integral)	0.0 to 100.0 repeats per minute
Rate (Derivative)	0.0 to 10.0 minutes
Cycle Time	1 to 240 seconds
Position Proportioning Sensitivity	0.0 to 50.0%
On/Off Hysteresis (width of hysteresis band)	0 to 300 units
First Output Position	-1000 to 1000 units
Second Output Position	-1000 to 1000 units
Automatic Transfer Function	User selectable to transfer from manual to automatic control when setpoint is reached Can be disabled.
Auto/Manual	Bumpless transfer from automatic to manual.
Manual Output	0 to 100%

ALARM ADJUSTMENTS

Process Alarm	-9999 to 9999 units
Deviation Alarm	-3000 to 3000 units
Deviation Band Alarm	1 to 3000 units
Hysteresis	0 to 300 units

CONTROL OUTPUTS

Relay SPST/SPDT	115 VAC: 5.0A Resistive, 1/8HP or 250VA 230 VAC: 2.5A Resistive, 1/8HP or 250VA
SSR Driver	Open collector output Short circuit protected @ 100mA maximum Provides 4VDC at 20mA or 3VDC at 40mA
mADC Current	4-20 or 0-20 mADC into 650 ohms maximum load

DISPLAY

Digital Display	Two- 4 digit possible; one per installed pen. Red LED's 0.56" high.
Status Indicators	LED indicators for Output 1, Output 2, Manual Operation, Alarm, Setpoint, minus sign and process value units.

RECORD

Chart	10 in circular chart; 100 charts furnished with each instrument if standard range
Chart Range	0 to 9999 units
Chart Drive	DC Stepper motor
Chart Rotation	User configurable from 0.1 to 999.9 hours per revolution
Pen Type	Disposable Fiber-tip
Pen Color	Pen 1-Red Pen 2-Green
Pen Response Time	<9 seconds over chart span
Accuracy	±1.0% of chart span max. error from displayed value
Chart Rotation Accuracy	±0.5% of Chart Rotation Time

DIGITAL COMMUNICATIONS

Type	RS-485 serial communications port. Half-duplex bi-directional communications.
Character Format	ASCII
Protocol	Per ANSI X3.28 subcategories 2.5 & A4
Configuration	User configurable to Monitor (read only) or Normal (read and write)
Bit Rate	User configurable to 300, 600, 1200, 2400, 4800, or 9600 bits per second
Address	User configurable for each pen; 0 to 99

Appendix E Recorder Only Software Reference/Record Sheet

ENABLE MODE	
ENAB	
EtSt	
ECAL	
EPro	
EASt	

ALARM SET		
	Pen 1	Pen 2
PAL1		
PAL2		
bAro		

PROGRAM MODE				
	Pen 1	Pen 2		unit
iSi1			rLyA	
iCi1			rLyb	
iSi2			rLyC	
iCi2			rLyd	
PEnS			rLyE	
rHC			rLyF	
AL1			rLyg	
AL2			rLyh	
dPoS			CurA	
Euu			Curb	
EuL			CurC	
HyAo			Curd	
Prnd			CoAr	
dFF			Cobr	
Pout			CoCr	
Pou			Codr	
PoL			Crt	
Cru			PAPu	
CrL			Coo	
PAEC			CCon	
			CbS	
			CAd1	
			CAd2	

Appendix F Recorder Controller; Recorder Controller Profiler Software Reference/Record Sheet

PROGRAM MODE				TUNE MODE		
	Pen 1	Pen 2	unit	Pen 1	Pen 2	
iSi1			rLyA	SoP		
iCi1			rLyb	PAL1		
iSi2			rLyC	dAL1		
iCi2			rLyd	bAL1		
PEnS			rLyE	PAL2		
rHC			rLyF	dAL2		
out1			rLyg	bAL2		
o1uL			rLyh	Pb1		
o1LL			CurA	Pb2		
out2			Curb	rSEt		
o2uL			CurC	ArS1		
o2LL			Curd	ArS2		
AL1			CoAr	rt1		
AL2			Cobr	rt2		
diSP			CoCr	rAtE		
dPoS			Codr	Ct1		
Euu			Ptb	Ct2		
EuL			PiA	SEnS		
HyCo			rrh	FoP		
HyAo			PPC	bAro		
rSP			Crt			
rSPu			PAPu			
rSPL			Coo			
SPuL			CCon			
SPLL			CbS			
AtFr			CAd1			
Prnd			CAd2			
dFF						
PFF						
Pout						
Pou						
PoL						
Cru						
CrL						
P1EC						
P2EC						
PAEC						

ENABLE MODE	
EtSt	
ECAL	
EPro	
Etun	
ESby	
EPC	
EPE	
ESPC	

P1	S1	S2	S3	S4	S5	S6
rt						
SP1						
SP2						
E1						
E2						
E3						
E4						
E5						
E6						
St						
E1						
E2						
E3						
E4						
E5						
E6						
PLCt=	dhru=	dhru=	dhru=	Pend=		

P2	S1	S2	S3	S4	S5	S6
rt						
SP1						
SP2						
E1						
E2						
E3						
E4						
E5						
E6						
St						
E1						
E2						
E3						
E4						
E5						
E6						
PLCt=	dhru=	dhru=	dhru=	Pend=		

P3	S1	S2	S3	S4	S5	S6
rt						
SP1						
SP2						
E1						
E2						
E3						
E4						
E5						
E6						
St						
E1						
E2						
E3						
E4						
E5						
E6						
PLCt=	dhru=	dhru=	dhru=	Pend=		

P4	S1	S2	S3	S4	S5	S6
rt						
SP1						
SP2						
E1						
E2						
E3						
E4						
E5						
E6						
St						
E1						
E2						
E3						
E4						
E5						
E6						
PLCt=	dhru=	dhru=	dhru=	Pend=		

P5	S1	S2	S3	S4	S5	S6
rt						
SP1						
SP2						
E1						
E2						
E3						
E4						
E5						
E6						
St						
E1						
E2						
E3						
E4						
E5						
E6						
PLCt=	dhru=		dhrd=		Pend=	

P6	S1	S2	S3	S4	S5	S6
rt						
SP1						
SP2						
E1						
E2						
E3						
E4						
E5						
E6						
St						
E1						
E2						
E3						
E4						
E5						
E6						
PLCt=	dhru=		dhrd=		Pend=	

P7	S1	S2	S3	S4	S5	S6
rt						
SP1						
SP2						
E1						
E2						
E3						
E4						
E5						
E6						
St						
E1						
E2						
E3						
E4						
E5						
E6						
PLCt=	dhru=		dhrd=		Pend=	

P8	S1	S2	S3	S4	S5	S6
rt						
SP1						
SP2						
E1						
E2						
E3						
E4						
E5						
E6						
St						
E1						
E2						
E3						
E4						
E5						
E6						
PLCt=	dhru=		dhrd=		Pend=	

Appendix G

Profile Development Sheet

The Profile Development Worksheet is intended to assist the Profile Recorder Controller customers. By filling in the worksheet with the application requirements, profile information can easily be obtained for entry into the instrument. The worksheet is a convenient record of the profile for future use.

A profile is a programmed sequence of setpoint changes over a period of time (**Ramp**) and setpoint maintained at a single point for a period of time (**Soak**). A sequence of a ramp and a soak is referred to as a **Segment**. A profile can contain from 1 to 6 segments. The instrument can store in memory up to 8 profiles.

The profile controllers can provide timed output relay action while running a profile, this is called an **Event**. Events may be selected as on or off as needed during each Ramp and Soak segment of the profile.

The first step to completing the worksheet is to determine the range of the setpoints necessary for the application. Fill out the setpoint scale along the left side of the worksheet. For dual pen profile controller be sure to scale the setpoint range for the greater range. Remember that the profile ramp will start at the process value indicated when the profile is initiated.

The next step is to sketch the profile outline on the worksheet. Use the setpoint scale to determine the setpoint levels. Draw each profile separately on a dual pen instrument. Be sure to fill in the time periods for each part of the segment in the boxes provided at the top of each column. The **Ramp** and **Soak** time boxes are located at the top of each column below the setpoint boxes for the segment. There are boxes at the bottom of each column to indicate the status of events, if used. If more than six segments are needed for the profile then individual profiles can be linked to perform sequentially. Linked profiles operate like one long profile.

Profile program information is easily determined by completing the Profile Developmental Worksheet for the application. The information derived within the worksheet is directly related to the profile entry parameters of the profile controller.

Profile Worksheet

Profile Number _____

Number of Segments _____

Segments	1		2		3		4		5		6	
	SP1	SP2	SP1	SP2	SP1	SP2	SP1	SP2	SP1	SP2	SP1	SP2
	Ramp Time	Soak Time	Ramp Time	Soak Time	Ramp Time	Soak Time	Ramp Time	Soak Time	Ramp Time	Soak Time	Ramp Time	Soak Time
Setpoint Scale												
Event 1												
Event 2												
Event 3												
Event 4												
Event 5												
Event 6												

Profile End Action _____

Profile Loop Count _____

Deviation Hold After Ramp Up _____

Deviation Hold After Ramp Down _____

Profile Time Base _____

Profile Interrupt Action _____

Sample Profile

The following is a sample profile intended to assist in understanding how the profile recorder functions. Be sure to disconnect all control outputs before running this profile. This profile does not make use of the second pen on a dual pen instrument to help keep the profile short.

Press and release the SCROLL key until **Prog** appears on the display then press the DOWN key. Press and release the DOWN key until **diSp** appears then press the SCROLL key. Press and hold the UP key until the display shows a 5 then press the SCROLL key. Press and release the Down key until **Ptb** appears then press the SCROLL key. Press and hold the UP key until a 3 appears then press the SCROLL key. Press the UP key and **Prog** will appear. Press and release the SCROLL key until **PEnt** appears then press the DOWN key. Perform the following keystrokes:

<u>Display</u>	<u>Keystroke</u>		
Pn	SCROLL	St	SCROLL
X	DOWN	X	UP/DOWN
1	SCROLL	0.10	SCROLL
Sn	SCROLL	rt	SCROLL
X	UP	X	UPDOWN
6	SCROLL	0.10	SCROLL
rt	SCROLL	SP	SCROLL
X	UP/DOWN	X	UP/DOWN
0.10	SCROLL	50	SCROLL
SP	SCROLL	St	SCROLL
X	UP/Down	X	UP/DOWN
100	SCROLL	0.10	SCROLL
St	SCROLL	PLct	SCROLL
X	UP/DOWN	X	UP/DOWN
0.10	SCROLL	2	SCROLL
rt	SCROLL	dHru	SCROLL
X	UP/DOWN	X	UP/DOWN
0.10	SCROLL	0	SCROLL
SP	SCROLL	dHrd	SCROLL
X	UP/DOWN	X	UP/DOWN
150	SCROLL	0	SCROLL
St	SCROLL	PEnt	SCROLL
X	UP/DOWN	X	UP/DOWN
rt	SCROLL	0	SCROLL
X	UP/DOWN	Pn	UP
0.10	SCROLL	PEnt	
SP	SCROLL		
X	UP/DOWN		
300	SCROLL		
St	SCROLL		
X	UP/DOWN		
0.10	SCROLL		
rt	SCROLL		
X	UP/DOWN		
0.10	SCROLL		
SP	SCROLL		
X	UP/DOWN		
200	SCROLL		
St	SCROLL		
X	UP/DOWN		
0.10	SCROLL		
rt	SCROLL		
X	UP/DOWN		
0.10	SCROLL		
SP	SCROLL		
X	UP/DOWN		
100	SCROLL		

With **PEnt** on the display, press and release the SCROLL key until **P 1** appears in the display then press RUN/ HOLD key. The display will show **run**, then display the ramping setpoint of the profile. This is to demonstrate how the profile recorder controller functions.

