

**TECHNICAL MANUAL**

**OPERATOR'S, UNIT AND  
DIRECT SUPPORT MAINTENANCE MANUAL  
(INCLUDING REPAIR PARTS AND SPECIAL TOOLS LIST)  
FOR**

**FOXBORO RECORDING GAUGE**

**This technical manual is an authentication of the manufacturer's commercial literature and does not conform with the format and the content requirements normally associated with Army technical manuals. This technical manual does, however, contain all essential information required to operate and maintain the equipment.**

**Approved for public release; distribution is unlimited.**

---

**HEADQUARTERS, DEPARTMENT OF THE ARMY  
28 SEPTEMBER 1990**

This technical manual is an authentication of the manufacturer's commercial literature and does not conform with the format and the content requirements normally associated with Army technical manuals. This technical manual does, however, contain all essential information required to operate and maintain the equipment.

Approved for public release; distribution is unlimited.

#### SUPPLEMENTARY INTRODUCTORY MATERIAL

##### 1-1. Maintenance Forms and Records

Department of the Army forms and procedures used for equipment maintenance will be those described by DA Pam 738-750, The Army Maintenance Management System

##### 1-2. Reporting Errors and Recommending Improvements

You can help improve this manual. If you find any mistakes or if you know of a way to improve the procedures, please let us know. Mail your letters, DA Form 2028 (Recommended Changes to Publications and Blank Forms), or DA Form 2028-2 located in the back of this manual, directly to Commander, U.S. Army Troop Support Command, ATTN: AMSTR-MCTS, 4300 Goodfellow Blvd, St Louis, MO 63120-1798. A reply will be furnished to you.

##### 1-3. Destruction of Army Material to Prevent Enemy Use

Refer to TM 750-244-3 for instructions covering the destruction of Army Material to prevent enemy use.

##### 1-4. Administrative Storage of Equipment

a. Placement of equipment in administrative storage should be for short periods of time when a shortage of maintenance effort exists. Items should be in mission readiness within 24 hours or within the time factors as determined by the directing authority. During the storage period appropriate maintenance records will be kept.

b. Before placing equipment in administrative storage, current preventive maintenance checks and services should be completed. Shortcomings and deficiencies should be corrected, and all modification work orders (MWO's) should be applied.

c. Storage site selection. Inside storage is preferred for items selected for administrative storage. If inside storage is not available, trucks, vans, Conex containers and other containers may be used.

**i/(ii Blank)**

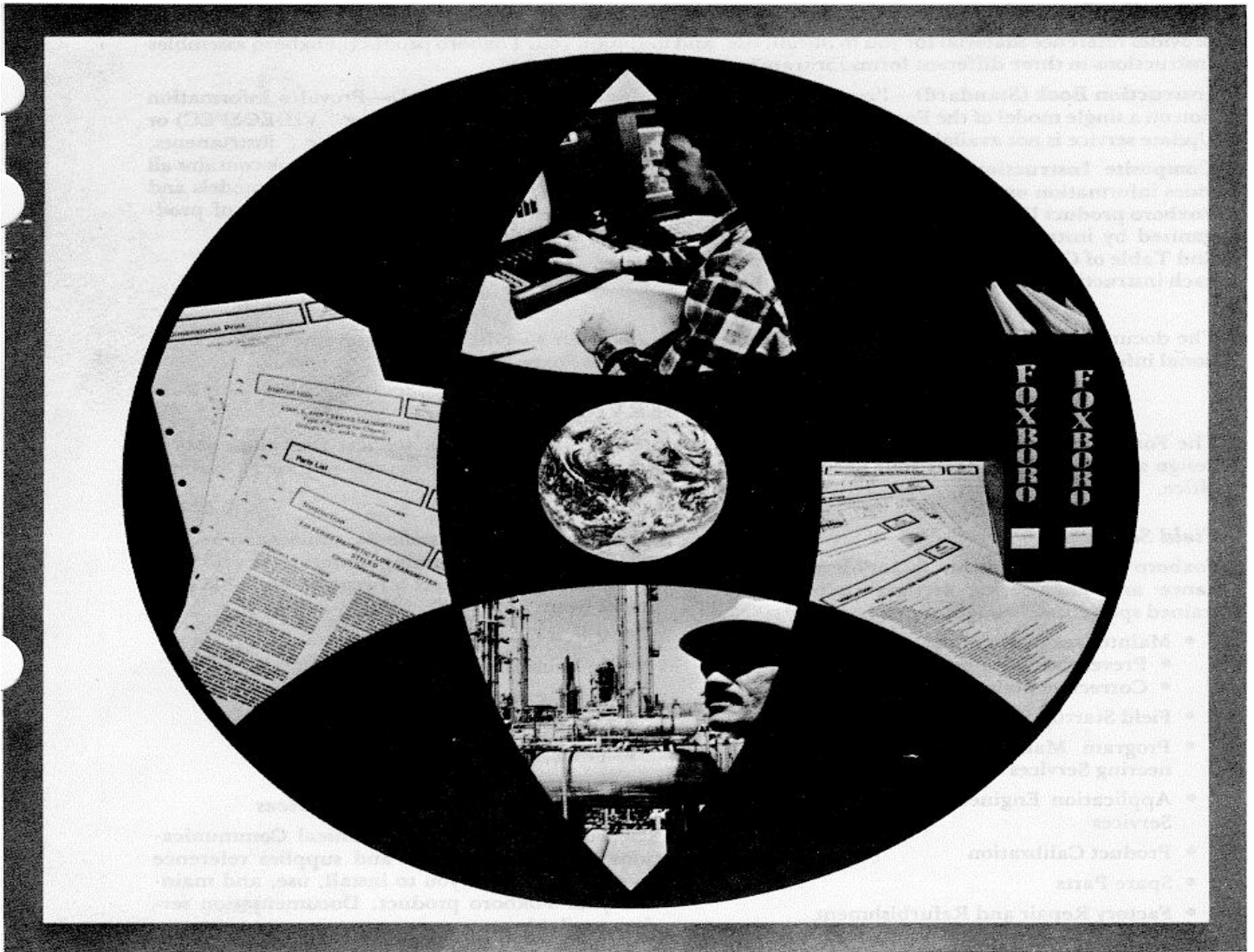

INSTRUCTION BOOK

- INSTALLATION
- MAINTENANCE
- PROGRAMMING
- OPERATION

2822

**FOXBORO<sup>®</sup>**

## ***This Book...***

provides reference material for you to install, use, and maintain your Foxboro product. Foxboro assembles Instructions in three different forms for transmittal to you. These are:

**Instruction Book (Standard)** - Provides information on a single model of the Foxboro product line. Update service is not available.

**Composite Instruction Book (Optional)** - Provides information on more than one model of the Foxboro product line. The book is sequentially organized by instruction number. A custom index and Table of Contents allows you to quickly locate each instruction. Update service is not available.

**Master Book (Optional)** -- Provides information on a specific product line (e.g., VIDEOSPEC) or group of Foxboro products (i.e., instruments, SPEC 200). The master or service book contains all issues of instructions pertaining to all models and styles of each specific product or group of products. Automatic update service is available.

The documents in this book have been assembled to match your specific order requirements. For additional information or to order additional copies, call your local Foxboro office.

## **FOXBORO SERVICES**

The Foxboro Company provides a wide range of maintenance and customer services that allow you to design a program that meets your needs. For more information on these services, call your local Foxboro office.

### ***Field Services***

Foxboro offers responsive, factory-level maintenance and engineering services performed by trained specialists through:

- Maintenance Programs
  - Preventive Maintenance
  - Corrective Maintenance
- Field Startup Services
- Program Management and Control Engineering Services
- Application Engineering and Programming Services
- Product Calibration
- Spare Parts
- Factory Repair and Refurbishment

### ***Educational Services***

Foxboro offers training courses through the Educational Services Department. Depending on your specific

training requirements, courses can be provided at worldwide training centers or at your own facilities. You can select a range of available programs from.

- Video-taped programs
- In-house courses
- On-site courses
- Self-study courses
- Textbooks

### ***Technical Documentation Services***

The Foxboro Corporate Technical Communications Department writes and supplies reference documentation for you to install, use, and maintain your Foxboro product. Documentation services available are:

- Standard product documentation
- Master book updates
- Additional documents

## **PREVENTIVE MAINTENANCE**

You must observe the following when performing maintenance on your Foxboro products:

- Install the product in its specified environment
- Schedule periodic preventive maintenance programs
- Service your Foxboro products using only Foxboro service personnel or other qualified service personnel
- Use only genuine Foxboro replacement parts

VIDEOSPEC and SPEC 200 are trademarks of The Foxboro Company.

## GENERAL INSTRUCTIONS

Foxboro designs, manufactures, and tests its products to meet many national and international standards. However, for these products to operate within their normal specifications, you must properly Install, use, and maintain these products. The following instructions must be adhered to and Integrated with your safety program when Installing, using, and maintaining Foxboro products.

- Read and save all instructions prior to installing, operating, and servicing the product.
- If you do not understand any of the Instructions, contact your Foxboro representative for clarification.
- Follow all warnings, cautions, and instructions marked on and supplied with the product.
- Inform and educate your personnel in the proper Installation, operation, and maintenance of the product.
- Install your equipment as specified in Foxboro site planning/installation instructions and per applicable local/national codes. Connect all products to the proper electrical and/or pressure sources.
- Handle, move, and install each product using the appropriate number of personnel and moving devices/equipment (dolly, forklift, crane, etc.) Failure to do so could cause serious personal injury.
- To ensure proper performance, use qualified personnel to install, operate, update, program, and maintain the product.
- When replacement parts are required, ensure that the qualified service technician uses replacement parts specified by Foxboro. Unauthorized substitutions may result in fire, electrical shock, other hazards, or Improper equipment operation.
- Ensure that all equipment doors are closed and protective covers are in place, except when maintenance is being performed by qualified personnel, to prevent electrical shock and personal injury.



® Registered Trademark

- INSTRUMENT MOUNTING -

ROUND-CASE RECORDERS AND INDICATORS

Select a location which is well lighted, free from vibration, and free from wide and sudden variations in temperature. Mount the instrument level on a rigid support.

Methods of Mounting and Dimensions

Flush (see Page 2)

Surface

Yoke

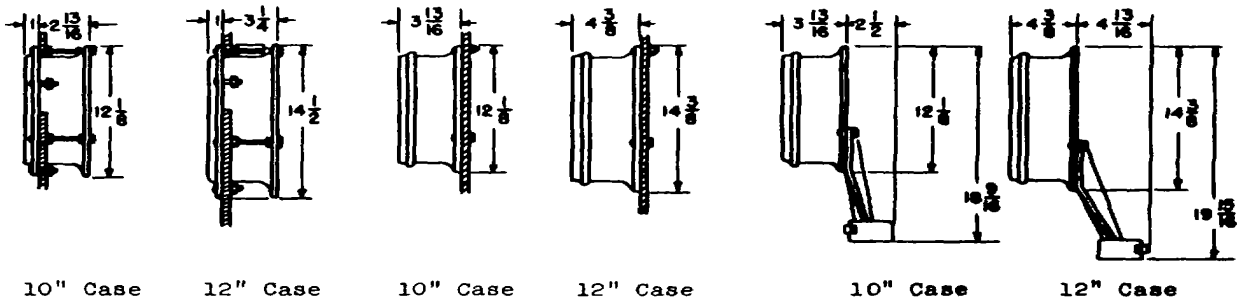

Yoke Mounting

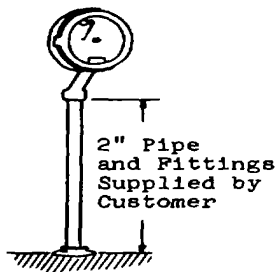

Surface Mounting Drilling Dimensions

Large dotted hole is unnecessary if element connections are made through barrel of case. If element connections are at rear, cut one large hole as indicated, or individual holes as required.

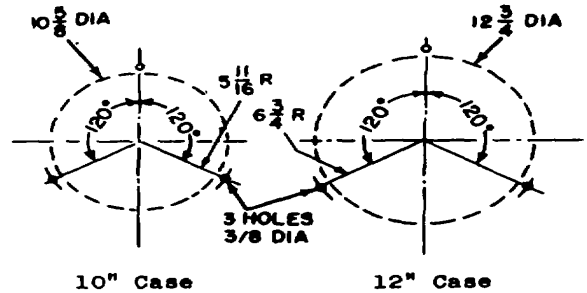

Element and Electric Connections

Pressure Connections

- 1/4 NPT female (up to 2000 psi)
- 1/2 NPT male (above 2000 psi)

Pneumatic Receiver Connections

- 1/4" compression fittings

Electric Connection

- 7/8" hole for 1/2" conduit

The Foxboro Company  
Foxboro Massachusetts U S A 02035



Printed in U S A

Flush Mounting Drilling Dimensions

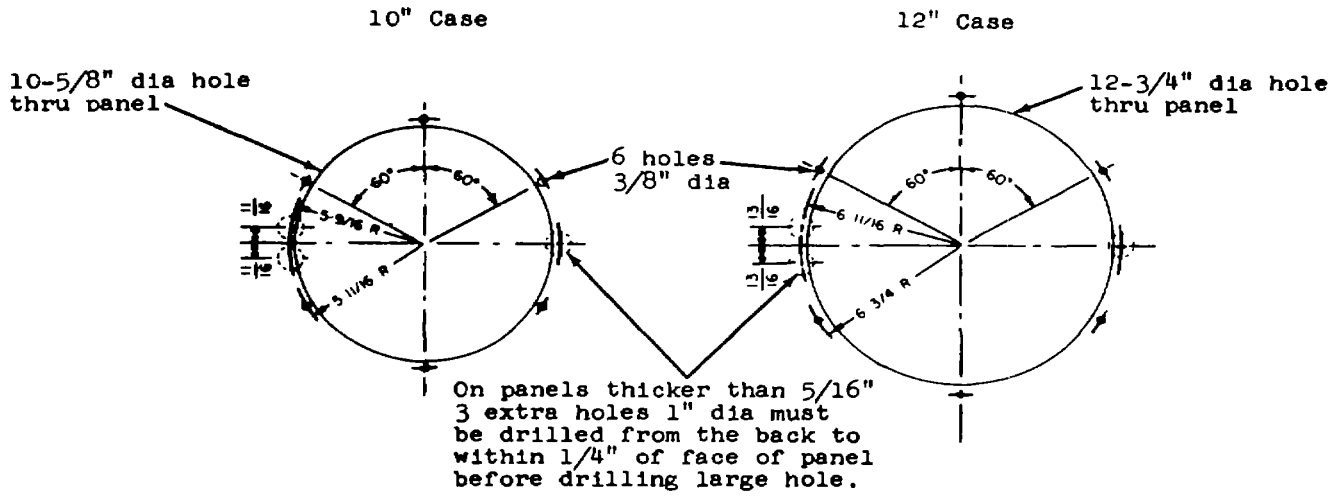

Flush Mounting Installation Details

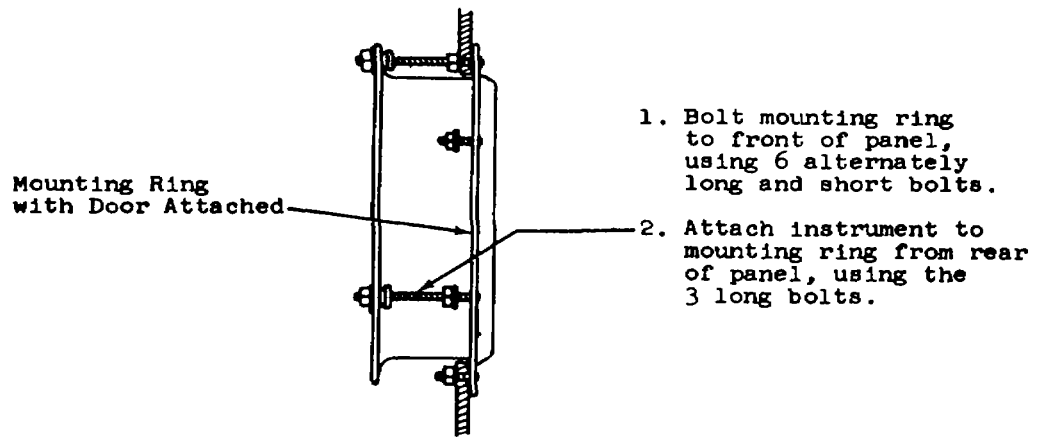

## GENERAL INSTRUCTIONS

Foxboro designs, manufactures, and tests its products to meet many national and International standards. However, for these products to operate within their normal specifications, you must properly install, use, and maintain these products. The following Instructions must be adhered to and Integrated with your safety program when Installing, using, and maintaining Foxboro products.

- Read and save all Instructions prior to installing, operating, and servicing the product.
- If you do not understand any of the instructions, contact your Foxboro representative for clarification.
- Follow all warnings, cautions, and instructions marked on and supplied with the product.
- Inform and educate your personnel in the proper Installation, operation, and maintenance of the product.
- Install your equipment as specified in Foxboro site planning/installation instructions and per applicable local/national codes. Connect all products to the proper electrical and/or pressure sources.
- Handle, move, and install each product using the appropriate number of personnel and moving devices/equipment (dolly, forklift, crane, etc.) Failure to do so could cause serious personal injury.
- To ensure proper performance, use qualified personnel to install, operate, update, program, and maintain the product.
- When replacement parts are required, ensure that the qualified service technician uses replacement parts specified by Foxboro. Unauthorized substitutions may result in fire, electrical shock, other hazards, or improper equipment operation.
- Ensure that all equipment doors are closed and protective covers are in place, except when maintenance is being performed by qualified personnel, to prevent electrical shock and personal injury.



Registered Trademark



# INSTRUCTION

**MI**  
001-410  
November 1983

## PENS, CHARTS, AND CHART DRIVES Round-Case Recording Instruments

### Pens

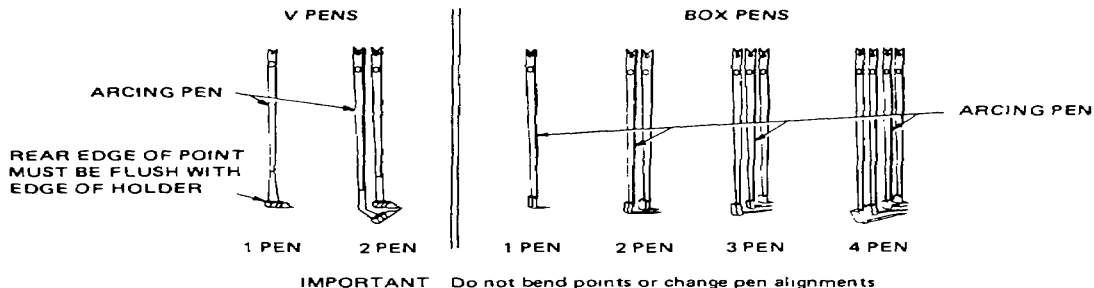

### Inks

Use only Foxboro Type 1800 ink. Its temperature limits are -35 and +65°C (-30 and +150°F). This ink is available in a variety of containers as shown in the adjacent table. Order by part number.

COLOR	PART NUMBERS				
	POLYETHYLENE BOTTLE			*CAPSULES **PACKETS	
	1 oz (30 mL)	1 PINT (470 mL)	1 GAL (3.8 L)	3 mL	2 mL
Red	C0131LG	F0100SF	F0100RS	C0132YP	F0104AP
Green	C0131LF	F100SL	F00100W	C0132YR	F0104AT
Blue	C0131LH	F0100SW	F0100RY	C0132Y0	F0104AS
Violet	C0131LJ	F0100SN	F0100SA	C0132YS	F0104AR
Black	C0131LK	F0100SR	R0100ST	-----	-----
Brown	-----	F0105CN	-----	-----	-----

### To Replace Chart

1. Raise pen filter
2. Pull out chart hub and remove chart.
3. Wind chart drive if mechanical. With 24-hour movement, if drive does not start, remove chart plate (see Page 3) and trip starter
4. Put on new chart, slipping it under time-set pointer.
5. Push in hub. Rotate hub so that correct time on chart is indicated by time-set pointer. Lower pen lifter

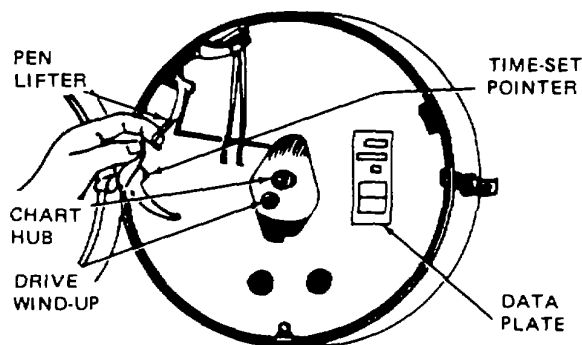

**FOXBORO**<sup>®</sup>

To Fill Pen

1. Add only enough ink so that supply is not used up before next filling.
2. After filling, replace protective bottle tip. If necessary, clean pen.

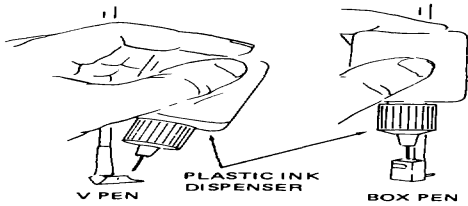

To Clean Pen

If a pen skips or is dirty, it must be cleaned. Detergent cleaners may be used, but every trace must be removed, or feathering will result. If long service wears a pen so that the inked line is too wide, replace the pen.

V Pen

Remove pen. Swab with fresh ink or hot water using pipe cleaner.

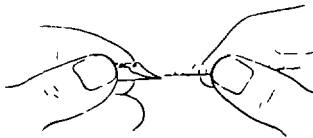

Box Pen

1. Remove pen.
2. Push 0.005 inch diameter wire (B & S #36 or Foxboro Part 0042527) through tip.
3. If necessary, prime pen (see section at right).

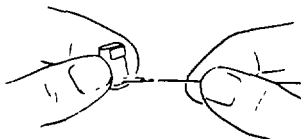

To Remove V Pen

1. Remove pen-arm (see section below).
2. Press point up. Point will snap out. Do not bend arm.
3. To reinstall, position parts as shown and press down. Rear edge of point must be flush with rear edge of holder.



To Remove Box Pen

Hold pen-arm and rotate box portion 90° Withdraw point from hole in arm.

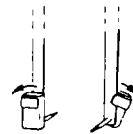

To Remove Pen-Arm

1. Gently pry upper end of pen-arm over stud. Then slide arm down.
2. Replace in reverse order
3. Rezero instrument if new pen-arm is used.

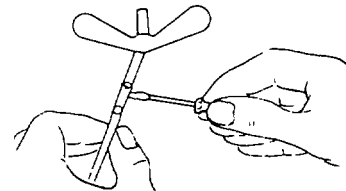

To Prime Box Pen

1. Remove pen and Fill box with ink.
2. Hold box as shown and squeeze to force ink out of tip. If pen still does not write, clean with wire (see section at left)

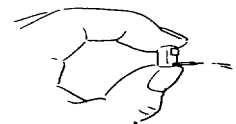

### To Remove Chart Plate

Aluminum Case  
(Rear of Case is Flanged)

1. Remove chart.
2. Push up locking latch (When relocking, push latch over step notch in chart plate.)
3. Remove chart plate by pushing to left so that edge of plate clears protruding lug. Then lift plate up and out to right. Replace in reverse order.

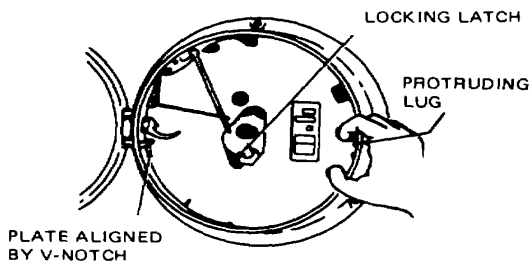

Steel Case  
(No Flange on Rear of Case)

1. Remove chart.
2. Remove chart plate by pushing up so that plate clears clip on lower column. Lift plate out over upper columns. Replace in reverse order.

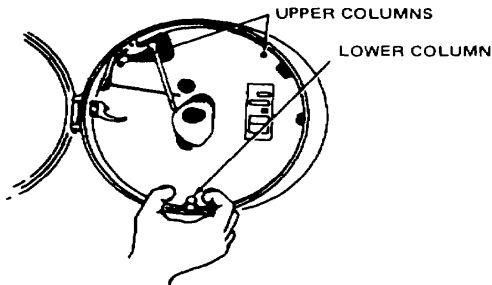

### Two-Speed Mechanical Chart Drive

To change speed, remove chart plate and rotate selector knob on drive in proper direction (to 7 Day or 24 Hour) as far as the knob will turn.

### To Remove Door

With aluminum case, tap hinge pin out.

With steel case, remove 3 screws holding door hinge. Longer screw in middle also holds pen lifter. Do not remove hinge pin.

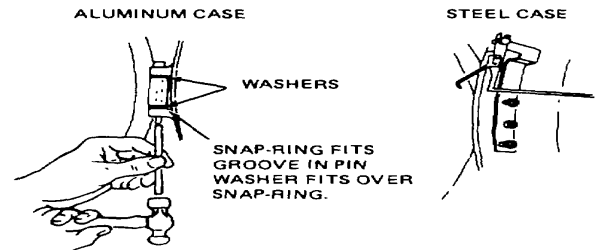

### To Adjust Path of Arcing Pen (Link-Connected Movements Only)

Note that only one pen--the arcing pen--traces a path that coincides exactly with the time arc on the chart. To identify the arcing pen, see the pen diagrams on Page 1.

1. Remove chart plate. Disconnect link from movement of arcing pen (note which hole link is in). Replace plate and chart. Move pen across chart by hand.
2. If path of pen requires adjustment, loosen the 2 mounting screws at base of movement and adjust eccentric screw until path of pen is satisfactory. Tighten screws and reconnect link. Adjust time-set pointer and check calibration.

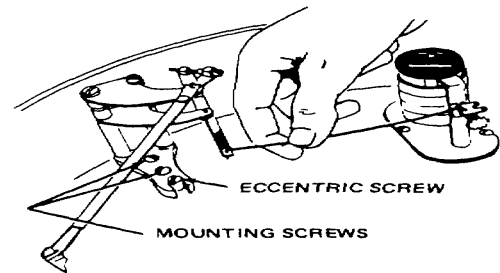



### Check for Dead Space and Excess Friction

Rap on recorder case while observing pen. If pen jumps to new reading, check for excess friction or play in linkage, for excess pen tension (see section at right), and for dirt in pen movement or linkage bearings. Bearings may be cleaned with trichlorethylene (or similar solvent), do not lubricate them.

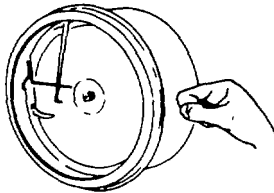

### To Replace Chart Drive

1. If chart drive is electric, turn off power and disconnect motor leads.
2. Remove chart hub by first removing center screw and then unscrewing base of hub. (A new hub is not included with a replacement chart drive.)
3. Remove the 3 mounting screws (Aluminum cases have chart plate latch mounted on lower screw .)
4. After replacing drive, check path of arcing pen (see Page 3) and check pen zero or reference adjustment (see calibration procedure on another instruction).

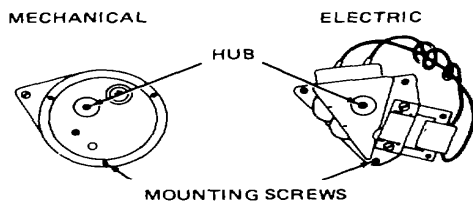

### To Adjust Pen Tension

If there is excess pen friction (see section at right), the pen tension should be checked as outlined below.

1. Chart disc must be flat. Check with straight edge and bend if necessary.



2. If recorder has V pen, rear edge of pen must be flush with edge of holder.
3. With link-connected movements, disconnect link so that pen can be moved by hand. With direct-connected movements, pen is moved by adjusting measured variable. Replace chart plate.
4. Check tension at 0, 50, and 100% of scale by pushing on plate directly under pen point.

The point should remain in contact with the plate for no more than 1.5 to 3 mm (0.06 to 0.13 in). If pen tension varies throughout the scale, check for a warped chart, or an improper mounting of the chart plate or chart drive.

5. If these three possibilities are eliminated and pen tension is still unsatisfactory, adjust tension by very slightly flexing pen arm inward. Just below rivet near top of arm.

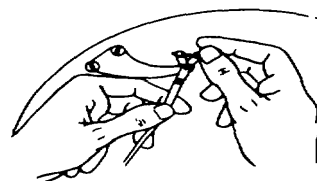

Chart Drive Lubrication

Electric chart drives require no additional lubrication under normal conditions.

Mechanical chart drives require cleaning and lubrication every 1 to 2 years, depending on local conditions.

Remove the chart drive from the instrument (see Page 4) and take the clockwork out of its case. The chart drive should be Fully run down or stopped. Partially insert the clockwork into a bath of clean trichlorethylene (or similar solvent), being sure to keep the mainspring out of the liquid. (IF liquid gets into the spring compartment it will be very difficult to remove it.) Wash all bearing surfaces, both inside and out, by brushing with a stiff brush saturated with solvent. Shake out all excess solvent and dry thoroughly.

Lubricate all bearing surfaces; contact parts of escapement, verge, and balance-wheel roller pin, using one of the following clock oils (available in 1 oz [30 mL] bottles).

CHART DRIVE MANUFACTURER	RECOMMENDED OIL	TEMPERATURE RANGE	FOXBORO PART NO.
Lux	Moebius No. 3	-30 to +650C (-20 to +150F)	F0100MR
	Moebius No. 3A	-40 to 35°C (-40 to +1000F)	F0100MS
Sonceboz	SYNT-A-LUBE	-20 to +50°C (0 to +120°F)	F0109EH

**FIBER-TIP PEN INKING SYSTEM**  
For 12R, 39A, 39B and 40 Series Recorders

**Operating Details**

The fiber-tip pen (with its self-contained ink supply) is a disposable unit that will continue to provide ink for approximately two months. (Assuming a relatively steady signal is present. With a fluctuating signal, pen life will be reduced.) When the ink supply is used up, a new pen is installed. The operating temperature limits of the ink are 5 and 500C (40 and 120°F).

These recorders can be equipped with up to four pen assemblies. Each pen assembly consists of a pen arm and a pen with a fiber tip. Pen arms are identified either by their length or by the number of holes (O to 3) in the

top (Figure 1); all pen arms on a recorder are different. A specific pen is used with each pen arm.

If a recorder has more than one pen assembly, the pen arms have different lengths to enable the pens to pass each other. Thus, only one pen in a recorder will exactly follow the time arc printed on the chart. This is called the arcing pen. The arcing pen is used for the measurement requiring the greatest accuracy.

The arcing pen arm is identified in Figure 1. All pen arms must be installed on their associated mounting brackets, and all pens must be installed on their associated pen arms (see table below and Figure 4).

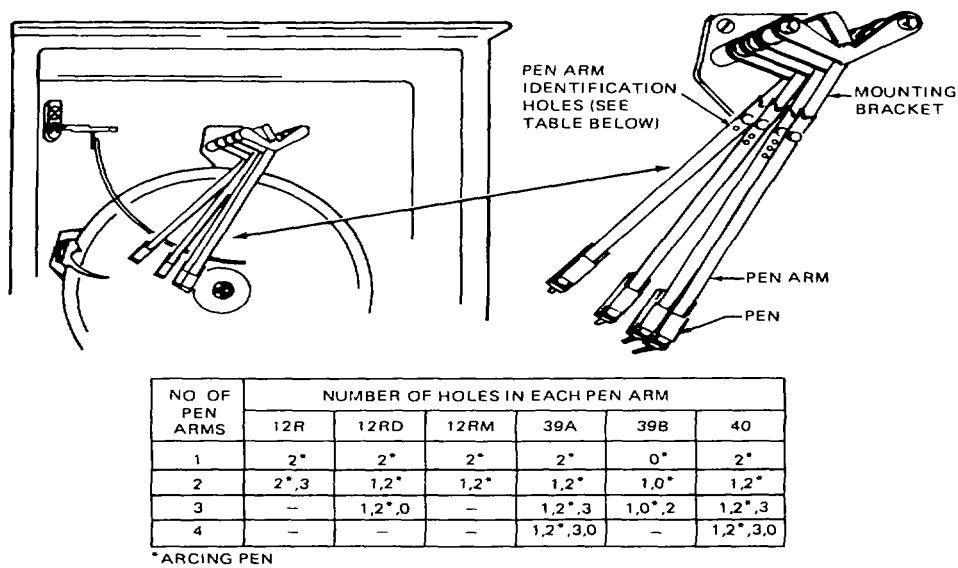

Figure 1.

**NOTE**

The pen arm length increases as read from left to right in the table. Also the pen arms are positioned innermost to outermost as read from left to right in the table.

Example: Given a 12RD with 3 pen arms. The first pen arm is the shortest and innermost and has 1 hole. The second pen arm (longer than, and outside the first pen arm) has 2 holes. The third pen arm (longest and outermost) has 0 holes.



### To Identify Pens

A pen may be identified by its part number which is located as shown in Figure 2. Pens are part numbered in each color for each pen neck length. For a list of part numbers, refer to Parts List PL 001-107.

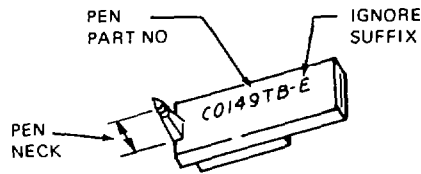
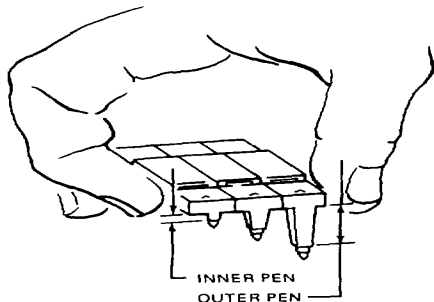

Figure 2.

The pens for a specific recorder can be identified for installation on their associated pen arms by the length of the pen neck (Figures 2 and 3).

Line up the pens as shown. (The protective cap on the fiber tip need not be removed at this time.) The pen with the shortest neck is installed on the inner pen arm. The pen with the next-longer neck is installed on the next-outer pen arm, etc. Figure 3.



### To Install New Pens

1. Determine on which pen arm, pen is to be installed.
2. Carefully insert end of this pen arm into mounting slot on top of pen, so that locking tab on front of pen snaps into small hole at end of arm (Figure 4).
3. Repeat procedure for remaining pens. Remove protective caps on fiber tips before use.

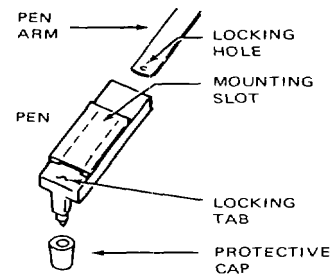
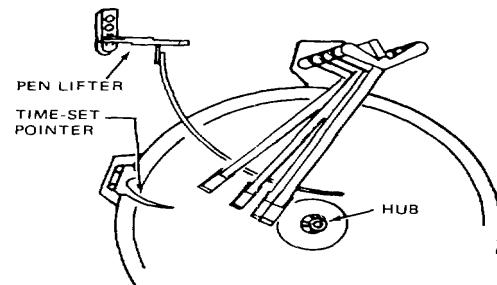

Figure 4.

### To Replace Chart

1. Raise pen lifter (Figure 5) and pull out hub of chart drive. Ease chart off of hub.
2. If chart drive is mechanical, wind spring motor.
3. Position new chart under time-set pointer and onto hub.
4. Push in hub, and rotate hub so that time-set pointer indicates correct time on chart. Lower Figure 5.





### To Remove Pen Arms

Gently pry up the upper end of the pen arm so that it is clear of the stud on the mounting bracket (Figure 6). Then slide the pen arm down off the bracket.

Reinstall the pen arm in the reverse order.

If a new pen or pen arm is being installed, rezero the recorder.

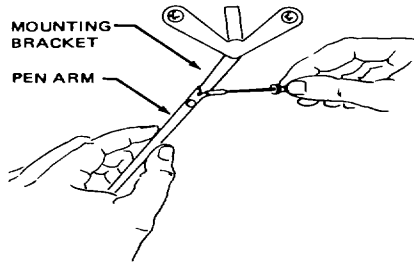

Figure 6.

### If Pen Does Not Write Properly

If a pen does not write properly, check the following points:

1. Ink supply exhausted; replace pen.
2. Debris on fiber tip; wipe off tip.

3. Insufficient pen tension on chart; see Instruction MI 001-435 for check.
4. If innermost pen is malfunctioning, check if pen lifter is holding fiber tip off chart. If necessary, bend lifter to a smaller curvature.

### To Order Replacement Pens

Replacement pens are available in packages of four. When ordering replacement pens, specify the part number from Parts List (PL) 001-107. For best results, put the pens into service prior to the date stamped on the package. See Figure 1 for pen-arm identification.

### To Replace Box Pens

Box pens can be replaced by fiber-tip pens. Order pens by part number; see "To Order Replacement Pens", above.

After fiber-tip pens are installed:

1. Adjust pen tension on chart to the minimum required value (see Instruction MI 001-435).
2. Rezero pen and check calibration.

ISSUE DATES

JAN 1984  
APR 1986

Vertical lines to right of text or illustration indicate areas changed at last issue date.

MB 100

0486

Printed In U S A

## CAPILLARY INKING SYSTEM

### Circular Chart Instruments

#### Starting the Capillary Inking System

1. If the ink supply bottles are mounted behind the chart plate, remove the plate. For details of this procedure, see other instructions.

2. Use only Foxboro Type 1800 ink. The color of the ink is determined by the color-coding on the bottle cap and on the pen-arm. Fill the bottles, and position the vent lines so that these lines are accessible from the front of the instrument.

3. Adjust the height of the bottles as indicated in Figs. 1 and 6. If the ink level is above the level of the pen tip, the hydraulic head will cause the ink to run out of the pen.

4. See Fig. 2. Pressurize the ink supply of each pen by introducing air into the vent lines by means of a squeeze bulb. Pressurize slowly until a drop of ink, free of any air bubbles, is expelled from each pen tip.

5. Replace the chart plate if it was taken off, and put a chart on the instrument.

6. Lower the pen lifter and rotate the chart manually. If any pen does not write, see Step 1 under Trouble Shooting. Push in the chart hub.

**IMPORTANT:** Each pen tip is individually ground, so that only when the correct pen is installed on the correct mounting bracket, will it properly ink the chart. Never bend or twist a pen tip.

#### Pen Identification

Standard capillary pens are identified by a letter (W, X, Y, or Z) etched on one side, and a two-letter designation etched on the other side. The one-letter designation refers to the mounting sequence of the pens on the instrument. The lower (in alphabetical order) lettered pen goes on the inner pen mounting bracket.

The two-letter designation is the suffix of the pen part number (the prefix is "M-122-") and further identifies the pen. Non-standard pens have their complete part number etched in place of the two-letter designation. Prior to the adoption of the two-letter designation, all capillary pens had only the one letter (W, X, Y, or Z) etched on them.

#### Adding Ink

A correctly installed pen will continue to write until the ink supply is used up. However, it is preferable to add ink whenever the ink level falls more than 1 inch.

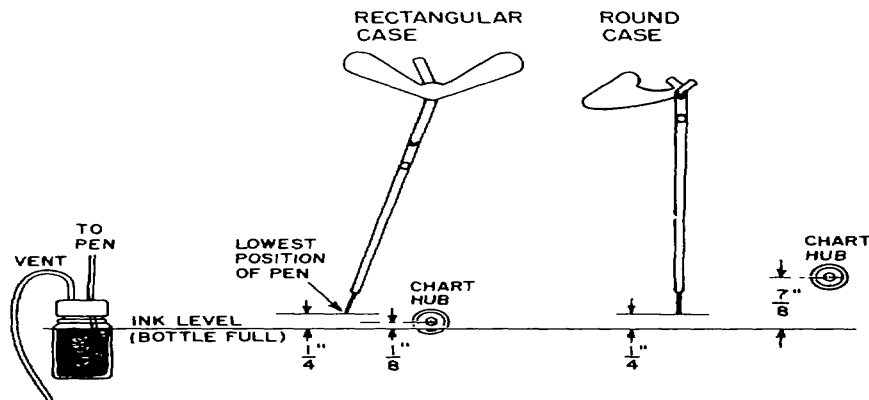

Fig. 1 Ink Level Location

The Foxboro Company

Foxboro, Massachusetts U S A 02035



Printed In U S A

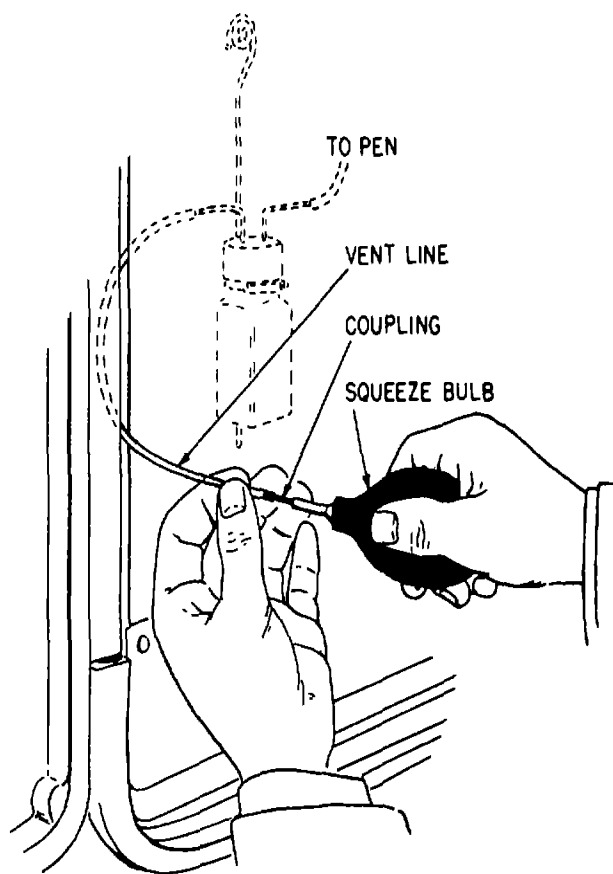

Fig. 2  
Pressurizing the Ink Supply

### CONVERSION FROM V-PEN OR BOX PEN TO CAPILLARY PEN SYSTEM

#### Parts Required

The parts required for the conversion of each conventional pen are an ink supply bottle (with its mounting bracket and plastic tubing assembly), the proper capillary pen, tubing clips, a pressurizing bulb, and an ink supply. Complete sets of parts to convert instruments to the Foxboro Capillary Inking System are available. When ordering such a set or individual parts, it is necessary to give the serial number appearing on the instrument data plate.

#### Installation

1. Remove the pens being replaced and the chart plate. For details on removing these parts, see other instructions.

2. Mount the ink bottle brackets to meet ink level, inspection, and maintenance requirements. See Figs. 1 and 6.

After refilling, remove any air bubbles by pressurizing the ink supply.

Caution: Lift the pen or pens off the chart when replenishing the ink supply.

#### Trouble Shooting

1. If a pen fails to write over the full range, look for air bubbles, plugged pen or vent, pinched tubing, leaks, low ink level, a bent or misfit pen, or insufficient pen tension (see Pen Tension Adjustment in other instructions).

To remove air bubbles, pressurize the ink supply with the pen disconnected.

A plugged pen may be cleared by pushing a 0.003 inch wire (Foxboro Part No. 49890) into the pen opening. Care must be used so that the edge of the opening is not burred. Restarting the pen should flush out the plugging material.

2. If a pen floods or produces an excessively wet record, it almost always is due to the level of the ink being too high. However, this condition may also be caused by a plugged vent.

3. Syphoning from one pen to another when chart records run together can be avoided by keeping the same ink levels in the bottles, and by keeping them as much as 1 inch below the pen tips if necessary.

3. See Table I in Parts List PL-1108 for the pen mounting sequence in various instruments. Put the inner pen on its mounting bracket. Arrange the tubing for this pen as shown in Fig. 3 (rectangular case), Fig. 4 (round case), or Fig. 5 (direct connected instrument). Repeat for each pen, starting with the next-to-the inner pen, and ending with the outer pen. It is essential that the tubing be installed so that it offers a minimum of resistance to the motion of the pen.

4. Sets of various colored tabs with adhesive backings are available. Put tabs of the same color on the bottle cap and pen-arm that go together.

5. Check the path of the time line arcing pen and correct if necessary.

6. For starting up and maintenance details see the first part of this sheet.

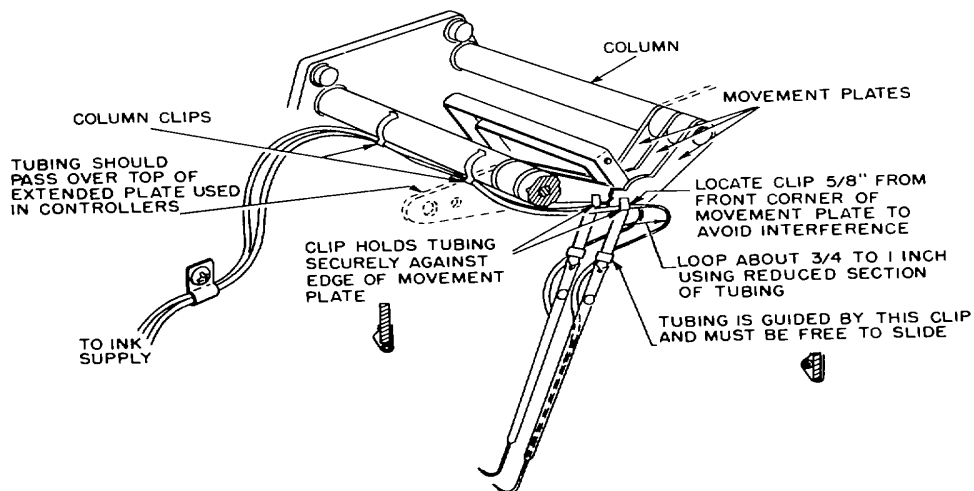

Tubing Arrangement in Rectangular-Case Instruments

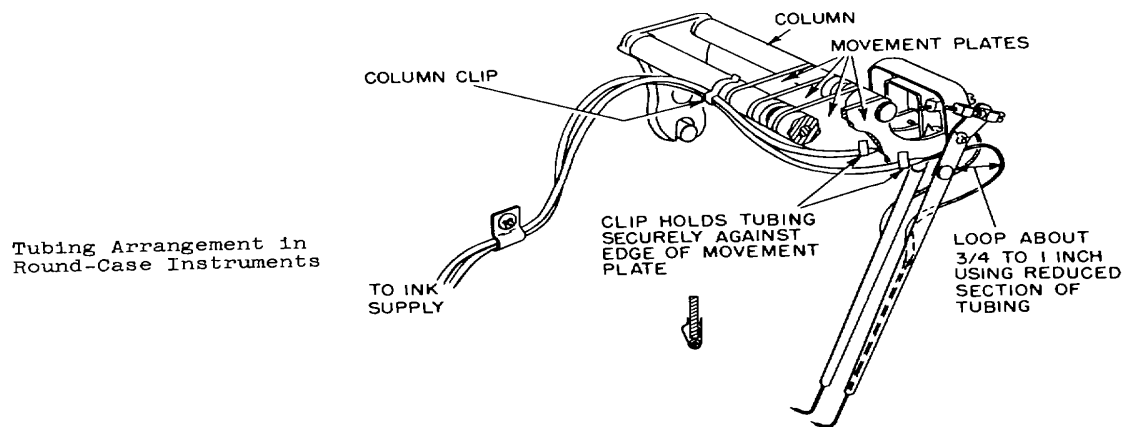

Tubing Arrangement in Round-Case Instruments

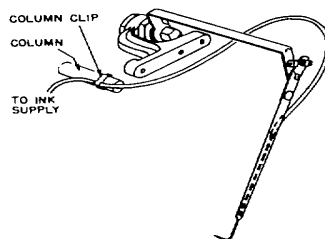

Direct-Connected Instruments

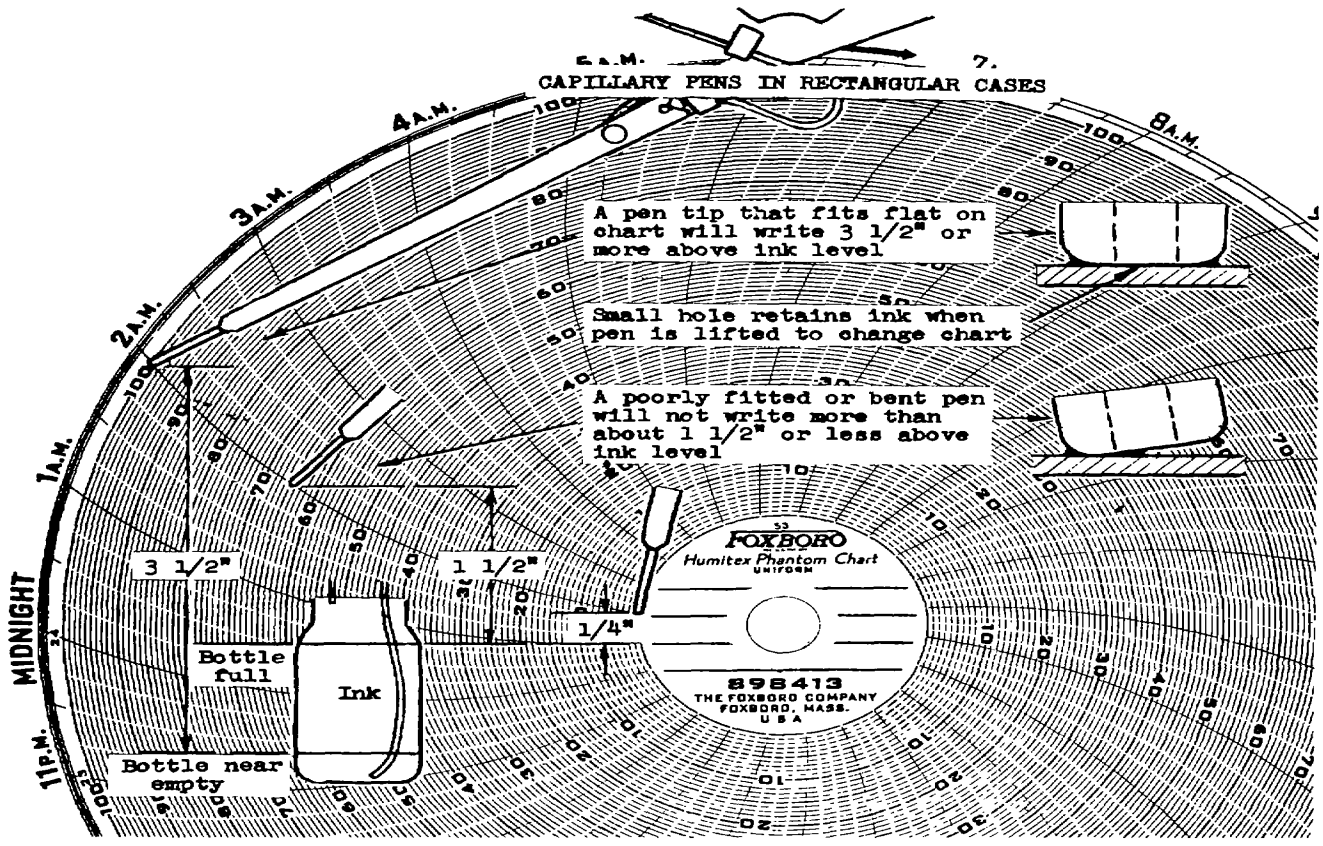

Fig. 6

The Foxboro Company

Foxboro Massachusetts U S A 02035



1000-5/63

Printed in U S A

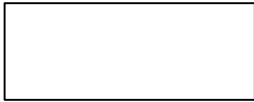

V AND BOX PENS,  
 PEN-ARMS, AND INDEXES  
 For Nominal 250 mm (10 Inch) Round-Case Instruments  
 Illustrations of parts below are ACTUAL SIZE.  
 Parts may be identified by matching with those shown.

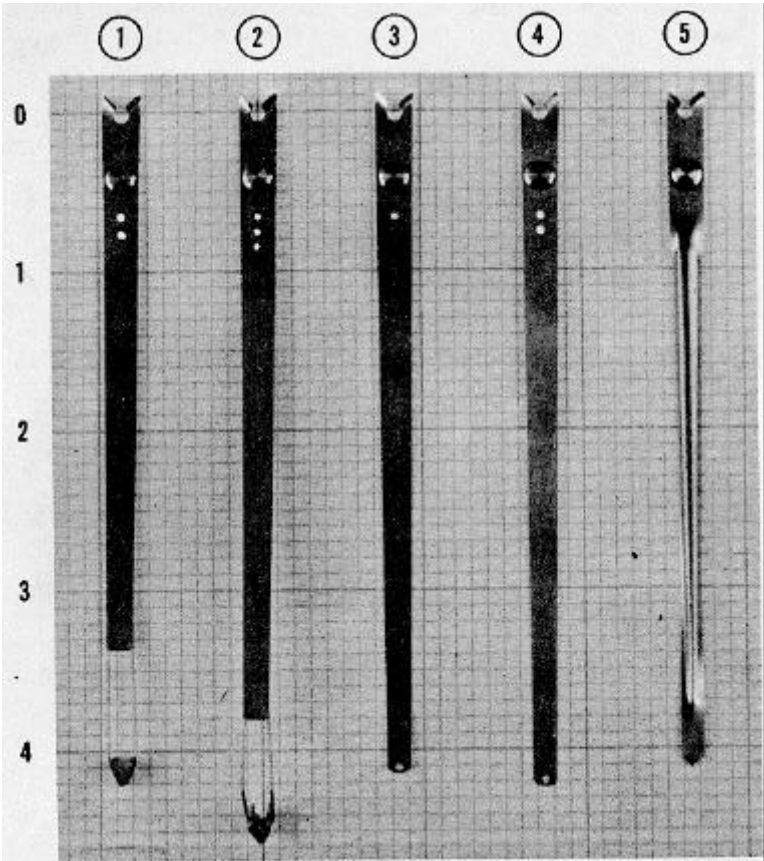

Fig. E1242

Item	Part Name	Number	Part Number	
			Violet	Red
1	V Pen Arm-Inner	2 0043996	-	M0122KP
2	Box Pen-Arm	-Inner	1	M0122AC
3	-Outer	3 0046967	M0122LP	M0122LN
4	-Outer	2 0044897	M0122LC	M0122LM
5	Setting Index	0 0032301	M0122LS	M0122LT



V AND BOX PENS,  
PEN-ARMS, AND INDEXES  
For Instruments in Nominal 300 mm (12 Inch) Round Cases  
or Rectangular Model 30 Cases  
Illustrations of parts below are ACTUAL SIZE.  
Parts may be identified by matching with those shown.

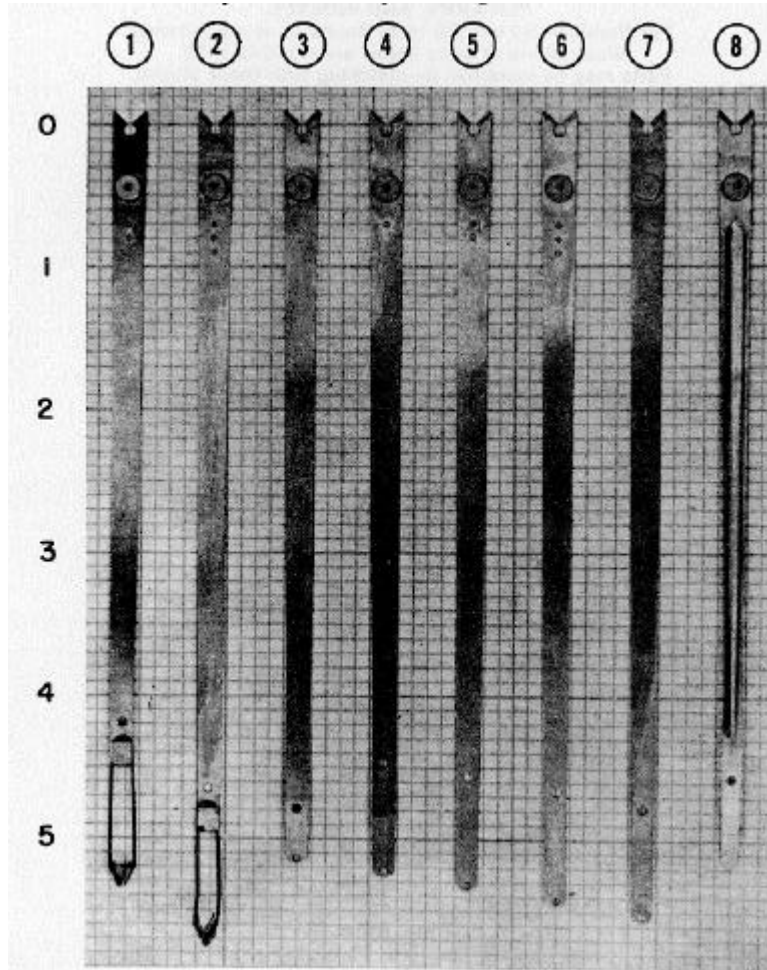

Fig. E1243

Item	Part Name	Number of Holes	No Color	Part Number		
				Violet	Red	
1	V Pen-Arm	-Inner	2	0043997	M0122KS	M0122KR
2	-Outer	3	0046963	M0122KW	M0122KT	
3	Box Pen-Arm	-Shortest		0		M0122NE
4	-Next to-Shortest	1		0046964	M0122KY	M0122KX
5	-Arcing	2	0044899	M0122LA	M0122KZ	
6	-Next-to-Longest	3		0046965	M0122LR	
7	-Longest	0	0046966		-	
8	Setting Index (disc)	0	0032490	M0122LW	M0122LX	



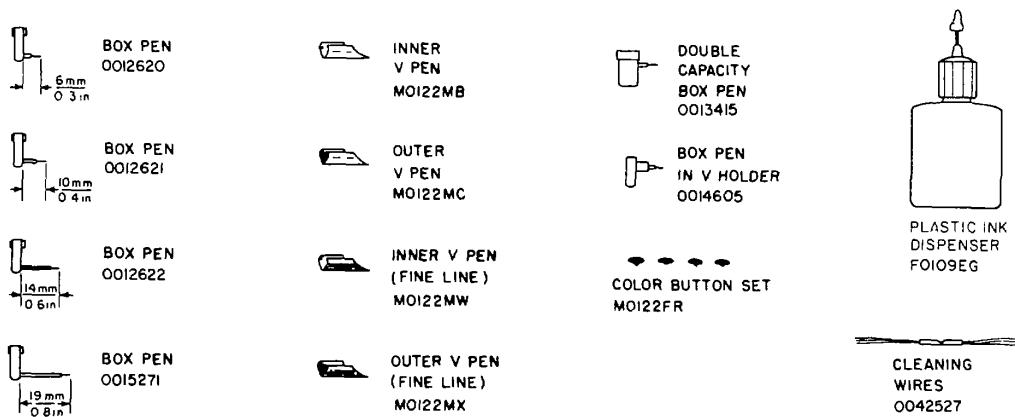

Fig. E2041A

Pen-arm part numbers given are for plain uncolored pen-arms. This sheet does not apply to uniform flow scale meters, nor to instruments with celluloid scales.

### Recorders

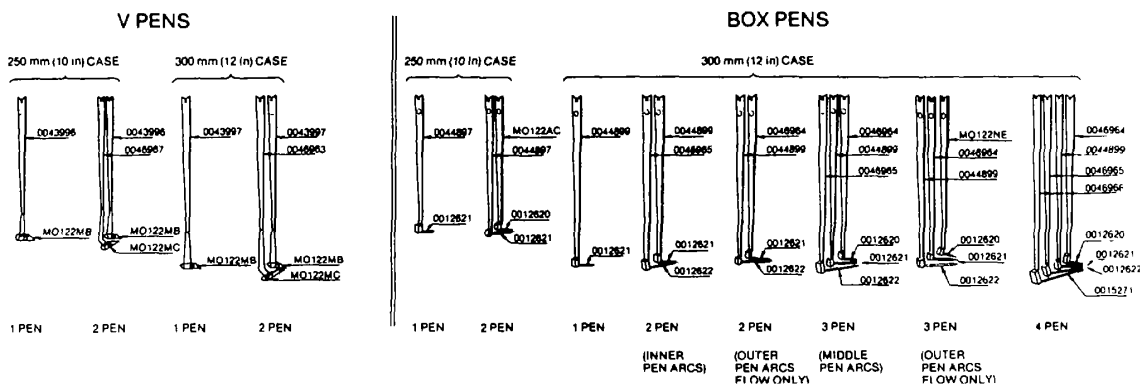

Fig. E1253A

Part numbers above are for plain, uncolored pen-arms and indexes. For corresponding colored items, refer to tabulations on Pages 1 and 2.

For *fine line* V-pens, specify Inner V-pen M0122MW in place of M0122MB, Outer V-pen M0122MX in place of M0122MC.

On two-pen instruments, there is a choice depending upon which pen is to follow the time arc. Since the pen arms are slightly different to permit their passing one another, only one of them can be precisely the right length to follow the chart time arc everywhere. The wire portions of V-pens may be bent slightly to permit arcing of either pen. In the case of box pens, however, only pen-arm 0044899 will arc exactly. The reading to be made with greatest precision should be recorded by this pen. On a flow instrument with static pen, the flow is read by the outer pen. Pen-arm 0044899 should be used on the outside, and arm 0046964 on the inside. Similarly on a 3-pen instrument with flow read by the outer pen, arm 0044899 is used on the outside, with arms 0046964 and M0122NE inside.





**DISPOSABLE FIBER-TIP PENS  
FOR  
CIRCULAR CHART RECORDING INSTRUMENTS**

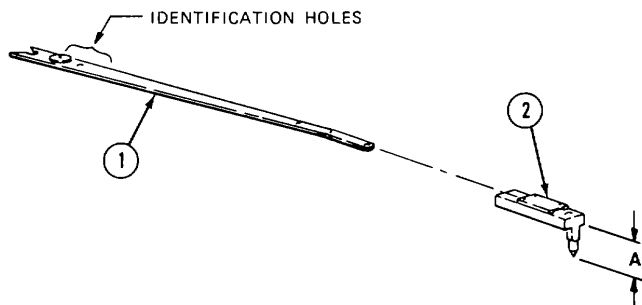

*Figure E2154*

12R Round Case Recorders

PEN ARM--ITEM 1		FIBER TIP PENS (PKG OF 4)--ITEM2			
IDENTIFICATION		A-LENGTH	COLOR	PART NO.	mm (in)
PEN LOCATION	PART NO.	HOLES			
1-Pen	0044899 2 red	C0149PW	12 (0.47)		
2-Pen inner	0044899	2	violet	C0149PV	6 (0.24)
outer	0046965 3	red	C0149PW	12 (0.47)	

12RD (1 to 3 pen) and 12RM (1 to 2 pen) Recorders

PEN ARM--ITEM 1		FIBER TIP PENS (PKG OF 4)--ITEM2			
IDENTIFICATION		A-LENGTH	COLOR	PART NO.	mm (in)
PEN LOCATION	PART NO.	HOLES			
1-Pen`	0044899 2 red	CO149TA	18 (0.71)		
2-Pen inner	0046964	1	violet	C0149TD	12 (0.47)
outer	1 0044899 2	red	C0149TA	18 (0.71)	
3-Pen inner	M0122NE	0	violet	C0149TO	12 (0.47)
center	0046964 1	red	C0149TA	18 (0.71)	
outer	1 0044899	green	C0149TC	24 (0.94)	

TO ORDER PARTS CALL FOXBORO AT 800-343-1198 (IN MASSACHUSETTS 800-322-2322).



**40, 40M, and 40P Rectangular Case Recording Controllers**

CONTROLLER TYPE	PEN LOCATION	PEN ARMS/INDEXES--ITEM 1		FIBER TIP PENS (PKG. OF 4)--ITEM 2		
		PART NO.	IDENTIFICATION HOLES OR COLOR	COLOR	PART NO.	A-LENGTH mm (in)
Single Action	1-Pen	0044897	2	red	C0149PW	12 (0.47)
	Index	0032301	plain			
Single Action with Add'l Pen	2-Pen inner	M0122AC	1	violet	C0149TD	12 (0.47)
	outer	0044897	2	red	C0149TA	18 (0.71)
	Index	M0122LT	red			
Single Action with 2 Add'l Pens	inner	M0122AC	1	violet	C0149TD	12 (0.47)
	3-Pen center	0044897	2	red	C0149TA	18 (0.71)
	outer	M0122AB	3	green	C0149TC	24 (0.94)
	Index	M0122LT	red			
Triple Setting	1-Pen	0044897	2	red	C0149TB	24 (0.94)
	Index, inner	M0122LS	violet			
	Index, center	M0122LT	red			
	Index, outer	M0122MA	green			
Ratio	2-Pen inner	M0122AC	1	violet	C0149TD	12 (0.47)
	outer	0044897	2	red	C0149TA	18 (0.71)
	Index	M0122LS	violet			
Ratio with Add'l Pen	3-Pen inner	M0122AC	1	violet	C0149TD	12 (0.47)
	center	0044897	2	red	C0149TA	18 (0.71)
	outer	M0122AB	3	green	C0149TC	24 (0.94)
	Index	M0122LS	violet			
Duplex	1-Pen	0044897	2	red	C0149TA	18 (0.71)
	Index, inner	M0122LT	red			
	Index, outer	M0122LS	violet			
Auto-Selector, Dual or Duplex with Add'l Pen	2-Pen inner	M0122AC	1	red	C0149TA	18 (0.71)
	outer	0044897	2	violet	C0149TF	24 (0.94)
	Index, inner	M0122LT	red			
	Index, outer	M0122LS	violet			

**40, 40M, and 40P Rectangular Case Recorders**

PEN LOCATION	PEN ARM--ITEM 1		FIBER TIP PENS (PKG. OF 4)--ITEM 2			
	PART NO.	IDENTIFICATION HOLES	COLOR	PART NO.	A-LENGTH mm (in)	
1-Pen	0044897	2	red	C0149PW	12 (0.47)	
2-Pen inner	M0122AC	1	violet	C0149PV	6 (0.24)	
	outer	0044897	2	red	C0149PW	12 (0.47)
3-Pen inner	M0122AC	1	violet	C0149PV	6 (0.24)	
	center	0044897	2	red	C0149PW	12 (0.47)
	outer	M0122AB	3	green	C0149PT	18 (0.71)
4-Pen inner	M0122AC	1	violet	C0149PV	6 (0.24)	
	next to inner	0044897	2	red	C0149PW	12 (0.47)
	next to outer	M0122AB	3	green	C0149PT	18 (0.71)
	outer	M0122AA	0	blue	C0149PU	24 (0.94)

Notes:

- On multiple pen recorders, if pens C0149TD (violet), C0149NA (black), C0149NN (green), or C0149N0 (blue) are used as arcing pens, then the red inner pen (C0149TZ) must be used. Its length is 6 mm (0.24 in).
- Black pens may be substituted for red or violet as follows:  
Use C0149MA for pen arm lengths of 12 mm (0.47 in)  
Use C0149NB for pen arm lengths of 6 mm (0.24 in)
- If replacing box pens with fiber tip pens, the color dot on the pen arm (item 1 in figure) must be removed.

**Available Pens**

A-LENGTH mm (in)	RED	VIOLET	GREEN	BLUE	BLACK
6 (0.24)	C0149TZ	C0149PV	C0149NM	C0149NP	C0149NB
12 (0.47)	C0149PW	C0149TD	C0149NN	C0149NQ	C0149NA
18 (0.71)	C0149TA	C0149NL	C0149PT	C0149NR	C0149NS
24 (0.94)	C0149TB	C0149TF	C0149TC	C0149PU	C0162AA



**BOTTLE TYPE CAPILLARY INKING SYSTEM**  
**Circular Chart Instruments**

**PENS**

**RECTANGULAR CASE INSTRUMENTS**

Pen Location		Recorder				Single Controller			Dual or Duplex Controller	
Position	Desig	1 Pen	2 Pen	3 Pen	4 Pen	1 Pen	2 Pen	3 Pen	1 Pen	2 Pen
In Case	nation			M0122PR	M0122PR		INDEX		INDEX	
Inner	W									
	X	M0122PW	M0122SE	M0122PW	M0122PW	M0122PW	MO122SE	M0122PW	M0122SE	INDEX
	Y		M0122SA	M0122PZ	M0122PZ		M0122SA	M0122PZ	M0122SA	M0122SA
Outer	Z				M0122RB				M0122SF	M0122SF

**ROUND-CASE INSTRUMENTS**

Pen Location	Desig	Recorder 300 mm (12 in)		Recorder 250 mm (10 in)	
		1 Pen	2 Pen	1 Pen	2 Pen
inside	w		M0122RL		MO122PR
Middle	X	M0122RK	M0122RK	M0122RK	MO122PW
Outside	Y			M0122RE	

**NOTE 1:** Standard capillary pens are identified by a two letter designation (the last two letters of the part number of the pen) etched on one side and a one letter designation (W X Y or Z ) etched on the other side of the pen. Non standard capillary pens have their complete part numbers etched in place of the two letter designation. Prior to the adoption of the two letter designation all capillary pens had only the one letter(W X Y or Z etched on them

**NOTE 2:** Pens M0122PW and SA are time line arcing pens

**OTHER PARTS**

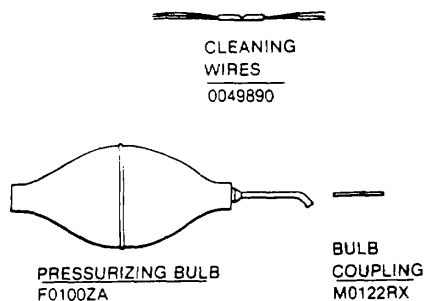

Fig. E2294

**NOTE 3:** Pens M0122PW and SA may also be furnished with brackets for segmental indicating scale linkages To order these bracket pens use part number M0122NR for the PW type and M0122SK for the SA type

**NOTE 4:** For capillary pens not listed in these tables consult The Foxboro Company for part numbers Be sure to include the serial number of the instrument

**INK**

TYPE 1800			
RANGE 35 to - 65°C (-30 to - 150°F)			
COLOR	BOTTLE SIZE		
	30 ml (1 oz)	470 ml (1 pt)	3 8 l (1 gal)
Red C0131LGF0100SF	F010orS		
Violet C0131 J	F0100SNF0100SA		
Green C0131LF	F0100SLF010orW		
Blue C0131LHF0100SW	F010orY		
Black C0131LK	F0100SRF0100ST		



**CLIPS**  
**INK BOTTLES AND TUBES**  
**(Obsolete Type)**

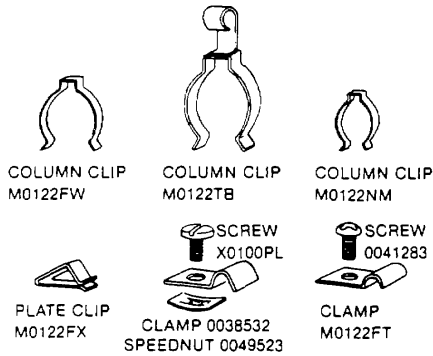

Fig. E2295

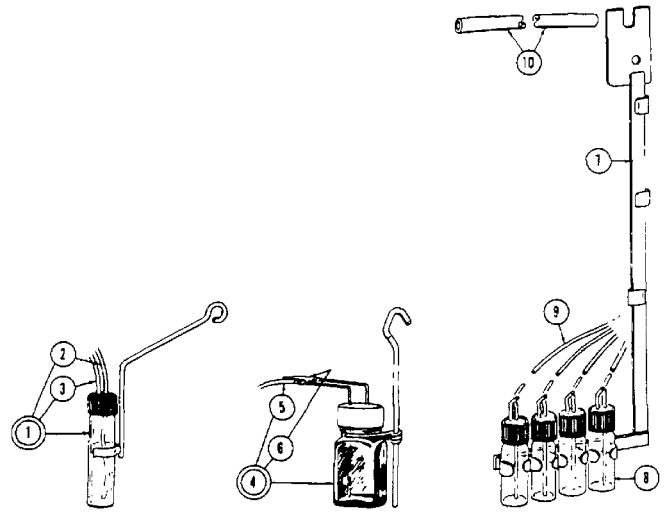

Fig. E2296

Item	Part No	Qty	Part Name
1	MC 22NZ	-	Pound Bottle Assembly 8 ml(1/4 oz):
2	R0 138CL	-	Tube (pen) 0 6 m 12 1t)
3	RO 128eY	-	Tubing (vent) 152 mm i6 in,
4	MC122PK	-	Square Bottle Assembly. 15 ml (1/2 oz)
5	R013CL	-	Tube (pen) 0 6 m 12 ft)
6	R01288Y	-	Tubing (vent) 140 mm 5 5 'n)

**CONVERSION KITS**

To convert to front loading capsule inking system-40 and 40P Series rectangular Instruments only Refer to instruction 1 443

Part No	Instrument
C0132RJ	1 Pen Recorder or Single Action Controller
C0132RK	2 Pen Recorder or Single Action Controller with additional pen
C0132RL	3 Pen Recorder
C0132UZ	Single Action Controller with 2 additional pens
C0132RM	4 Pen Recorder
C0132YE	2 Pen Dual or Duplex Controller
C0132YF	1 Pen Duplex Controller

MB 50

Item	Part No	Qty	Part Name
7	M0122TZ	1	Bottle Holder Assembly (1 pen)
7	MO 122WE	1	Bottle Holder Assembly (2 pens)
7	M0122WM	1	Bottle Holder Assembly (3 pens)
7	M0122TE (disc )		Bottle Holder Assembly (4 pens)
8	M0122TS	1 2 3,4	Bottle Assemblies
9	R0138CL	1,2,3,4	Tubes 0 6 m 2 ft each
10	0022917	-	Tubing (1 pen) 165 mm (6 5 in)
10	0035070	-	Tubing (2 3 or 4 pens) 165 mm 6.5in)

NOTE For superseding type capillary Inking system refer to PL001 109



**CHART DRIVES**

Mounting Parts For Rectangular Case Chart Drives

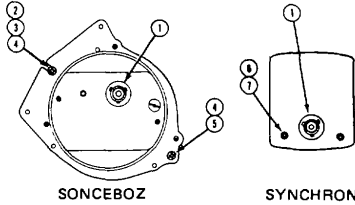

Figure R1211

Mechanical Electric

Item	Part No	Qty	Part Name	Item	Part No	Qty	Part Name
1	M0103AA	1	Chart Hub Assembly	1	M0103AA	1	Chart HubAssembly
-	M0103AE	1	Chart Hub Screw	-	M0103AE	1	Chart Hub Screw
2	M0146AZ	1	Eccentric Post Assembly 32 x 0 250	6	0040383	2	Screw, pnh, 0.164-
3	0044567	1	Locknut 7	MH0130PL		2	Column
4	X01270C	2	Screw, pnh, 0 190-32 x 0.312				
5	H0146BC	1	Column				

Mounting Parts For Circular Case Chart Drives

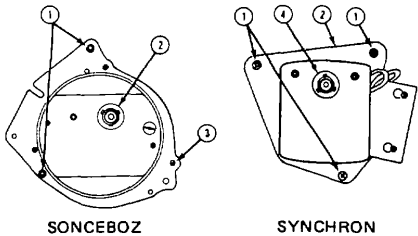

Figure R1212

Mechanical Electric

Item	Part No	Qty	Part Name	Item	Part No	Qty	Part Name
1	0010441	2	Screw. rdh, 0.125-40 x 0 250 40 x 0.250	1	0010441	3	Screw, rdh, 0.125-
2	MOIO3AA	1	Chart Hub Assembly	2	H0103AA	1	Chart HubAssembly
-	MO103AE	1	Chart Hub Screw	-	M0103AE	1	Chart Hub Screw
3	0005137	1	Screw,rdh, 0 125 40 x 0 187 40 x 0.187	3	0005137	1	Screw. rdh, 0.125-
-	0035932	3	Column (deep case) Assembly	4	M0154CN	1	Mounting Set
-	0035932	3	Column (deep case)				



**Sonceboz Mechanical Chart Drives**

PART NO.	ROTATION	WIND	FEATURES
MO152KM	8hr 24 hr		
MO152KL	12 hr 24 hr		
MOIS2KF	24 hr 7 day		
HO152KN	48 hr 7 day		
MO1S2KK	7 day 7 day		
NO1S2KT	8 day 8 day		
MO154FT	31 day 31 day		
A085447	7 day 7 day	-30 and -SOC	(-20 and -600F) lubrication
HO152KP	24 hr/7 day	7 day	two-speed
NO152KW	24 hr/8 day	8 day	two-speed
A089018	24 hr/7 day	7 day	two-speed, -30 and -SOC (-20 and -600F) lubrication

**Mechanical Chart Drive Lubricants**  
**(1 oz. Bottles)**

CHART DRIVE MANUFACTURER	RECOMMENDED OIL RANGE	TEMPERATURE PART NO.	FOXBORO
Sonceboz	SYNT-A-LUBE (0 to + 1200F)	-20 to +50°C	F0109EH

**Rockwell (Macnick) Chart Drives**

Chart Drive 0049932 --24-hour rotation 8-day wind  
 Chart Drive 0047539 --7-day rotation 31 day wind (11 jewels)  
 Part MO146TF --Chart Hub for Rockwell Chart Drives

**Speed Change Turrets**

Turret for 24-hour chart drive to give 7-day rotation -- Part 0049933  
 8-day rotation -- Part M0146RE  
 Turret for 7-day chart drive to give: 31-day rotation -- Part MO146RK  
 16-day rotation -- Part MO146RL  
 24-hour rotation -- Part MO146SA

**Mounting Columns**

<u>Part No.</u>	<u>Qty.</u>	<u>Description</u>
M0146YY3		Chart drive without adapter plate
M0127AR3		Chart drive with adapter plate

**Winding Key**

<u>Part No.</u>	<u>Description</u>
0034794	2 7 inch shank



**Electric Chart Drives**

Synchron		
Voltage Complete Rotation and Chart Period Frequency Drive	Motor	
115 V, 60 Hz M0132PA 1230 V, 60 Hz A063194 Hour 115 V, 50 Hz 230 V, 50 Hz A063196	MO132MR A063146 A063195 A063145	A063137
115 V, 60 Hz M0132PE 6230 V, 60 Hz A063201 Hours 115 V, 50 Hz 230 V, 50 Hz A063203	M0132MT M0132MW A063202 M0132MY	MO132MX
115 V, 60 Hz MO132PF 8230 V, 60 Hz A063204 Hours 115 V, 50 Hz 230 V, 50 Hz A074920	MO132MZ A063142 AO071189 A074921	Figure B8240
115 v, 60 Hz M0132PK 12230 V, 60 Hz A063205 Hours 115 V, 50 Hz 230 V, 50 Hz A063206	MO0132MT M0132MW M0132PL M0132MY	MO132MX
115 V, 60 Hz MO132PN 24230 V, 60 Hz M0132PP Hours 115 V, 50 Hz 230 V, 50 Hz MH0132PS	MO132NC MO0132NE M0132PR M0132NK	M0132NF
115 V, 60 Hz M0132PY 7230 V, 60 Hz MO132PZ Days 115 V, 50 Hz 230 V, 50 Hz M0132RB	M0132RF MO132RK M0132RA MO132RM	MO132RL



SYNCHRON MOTOR

Other rotation periods, voltages, and frequencies available

**Battery-Operated Chart Drives**

**Mercury Instruments Incorporated**

24 hour rotation -- Part AO93321  
7-day rotation -- Part A093322  
8 day rotation - Part A093323  
31-day rotation -- Part A093324  
Battery Clip - Part A093295  
1.5 V Battery-- Part A089701

**Wilson Instruments Incorporated**

1-, 2-, 4-, 7 , 8-, 16 , 31-,  
and 32 day rotation -- Part MO155AZ  
Adapter Plate -- Part M0155KA

**Sonceboz Corporation**

Chart Drive (without time programmer) -- Part MO1SSPH  
24-hour plug-in time programmer -- Part MO15SPJ  
7-day plug in time programmer -- Part MO1SSPK  
8-day plug-in time programmer -- Part MHO15SPL  
16 day plug in time programmer -- Part MO0155PZ  
31-day plug in time programmer -- Part HOISSPM

**Pneumatic Chart Drives**

Part MO0146YS -- 24 Hour Rotation  
Part A044377 -- 24 Hour and 7 Day Rotation

**Mounting Parts**

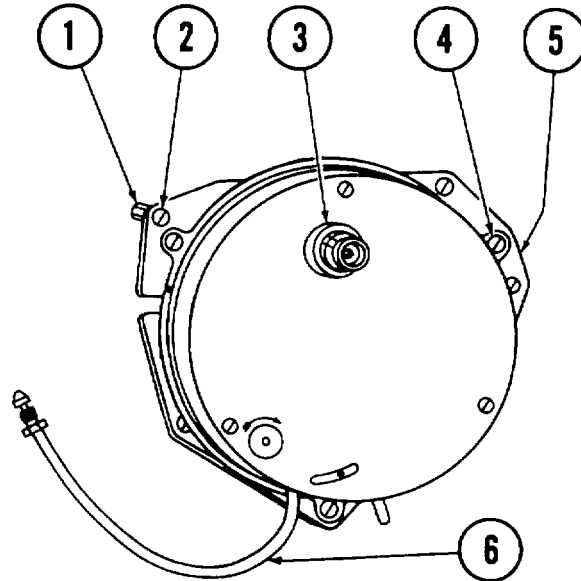

Figure E1848

**Rectangular Cases**

<u>Item</u>	<u>Part No</u>	<u>Qty</u>	<u>Part Name</u>
1	M0100BE	3	Column
2	0033614	3	Screw, rdh, 0.125-40 x 0.375
3	M0103AA	1	Chart Hub Assembly
-	M0103AE	1	Chart Hub Screw
4	0013262	3	Screw, rdh, 0.125-40 x 0.187
5	MO146YW	1	Mounting Plate
6	M0146YX	1	Tube Assembly

Note: For gas operation, add M0152FA Exhaust Tube

**Circular (12 R) Steel Cases**

<u>Item</u>	<u>Part No</u>	<u>Qty</u>	<u>Part Name</u>
1	0035932	3	Column
2	0034176	3	Screw, flh, 0.125-40 x 0.250
3	M0103AA	1	Chart Hub Assembly
-	M0103AE	1	Chart Hub Screw
4	0013262	3	Screw, rdh, 0.125-40 x 0.187
5	MO146YW	1	Mounting Plate
6	A036023	1	Tube Assembly



**12R CIRCULAR CASE RECORDER**  
**Styles A and B**

**Model Code**

12R = 12 Inch Circular Case Recorder

Mounting

- F = Flush
- P = Portable
- S = Surface
- Y = Yoke

Chart Drive

- E = Electrical 24 Hour 120 V, 60 Hz
- M = Mechanical 24 Hour Rotation and 7 Day Wind
- X = None or per AS

Pen And Type

- 1 = One
- 2 = Two
- F = Fiber Tip Disposable
- V = V-type (not with 3 Pens)
- B = Box Type
- C = Capillary



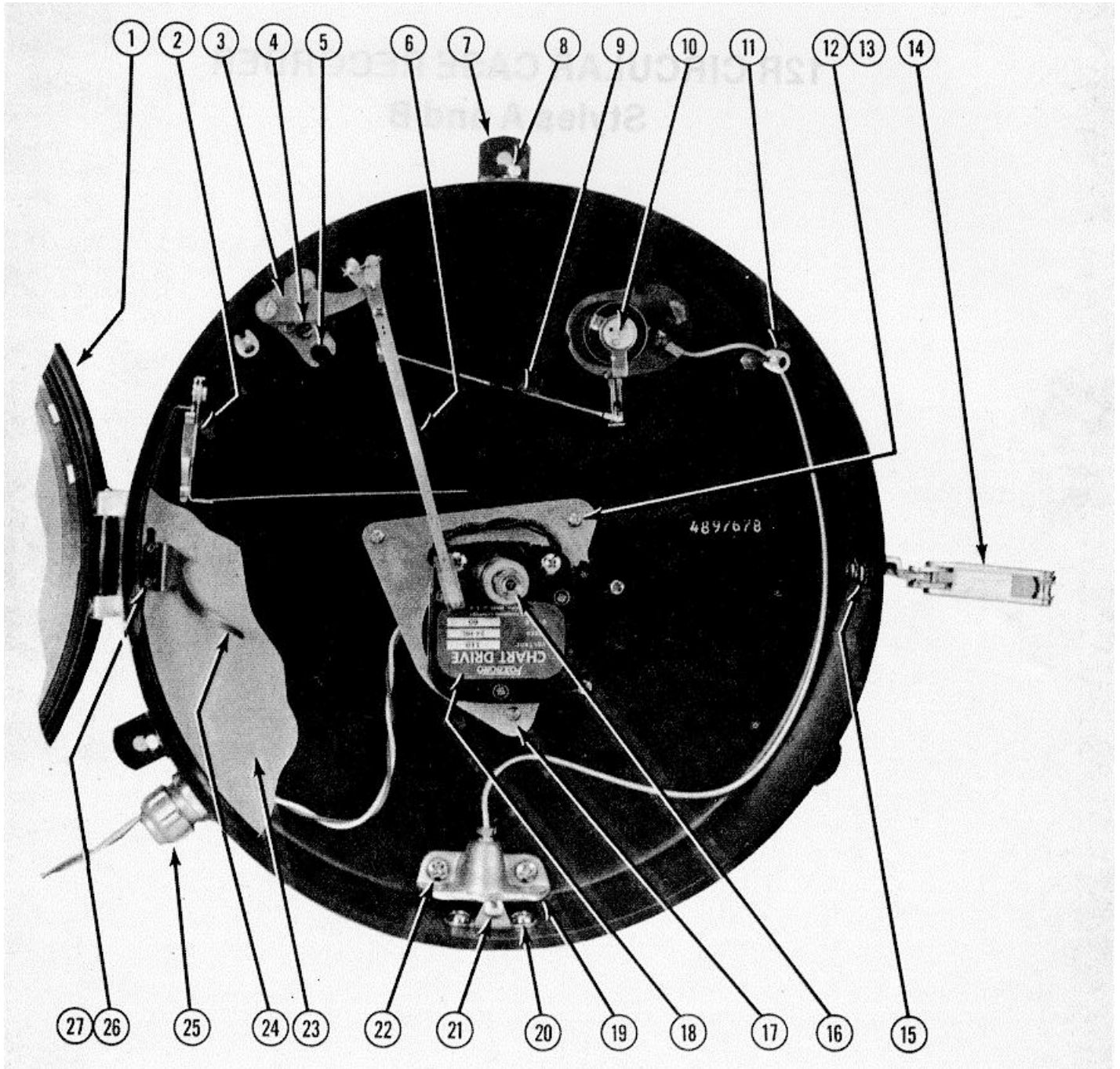

Figure R1203

Item Part No Qty Part Name

1	1		Door Assembly (see PL 001-217)
--	0020473	2	Screw, filh, 0 164-32 x 0.437 (for hinge)
--	0020470	1	Screw, filh, 0.164-32 x 0.375 (for hinge)
2	M0138AW	1	Pen Lifter Assembly
3	1		Pen Movement Assembly (give serial number)
4	X0I00ZA	1	Screw, rdh, 0 164-32 x 0 375
5	0029405	1	Eccentric Screw
6	--		Pens and Pen Arms (see PL 001-001 and PL 001-107)
7	M0138AC	3	Mounting Bracket (for surface mounting)
8	X0100CP	3	Screw, Sems, hexh, 0 250-20 x 0 375
9	--		1-2 Link, Adjustable (give serial number)
10	-		1-2 Measuring Element (give serial number and range)
11	Below	2	Column Assembly (for chart plate)
	M0138AY	2	34 in, for shallow case
	M0138CS		3.64 in. for deep case
12	0010441	2-3	Screw, rdh, 0.125-40 x 0.250
13	Below	3	Column
	0035932		0 285 in, for shallow case
	D010SBE		1.438 in, for deep case
14	M0138CY	1	Hasp Assembly
15	0004120	2	Screw, Sems, rdh, 0 190-32 x 0.375
16	M0103AA	1	Chart Hub Assembly
-	M103AE	1	Chart Hub Screw
17	M00154CN	1	Chart Drive Mounting Kit (for electric chart drive)
18	Below	1	Chart Drive, 24 hr Rotation (see note)
	M0132PN		120 V, 60 Hz
	M0152KF		Mechanical, 7 day wind
19	Below	1	Pressure Connection (when used)
	0021425		1/4 NPT, brass, to 2000 psi, back or bottom conn.
	0049541		1/4 NPT, ss, to 2000 psi, back or bottom conn.
	P0104BN		1/2 NPT, ss, over 2000 psi, bottom or side conn.
	P0104BR		1/2 NPT, ss, over 2000 psi, back conn.
	P0104XR		1/2 LL Union, back connection
	0039765		1/2 LL Union, bottom connection
20	0032508	2	Screw, rdh, 0 218-24 x 0 250
21	MH0138AP	1	Bracket Assembly (for chart plate)
22	Below	2	Screw, rdh,
	X0I00CM		0.250-20 x 0 437. for back connection
	X0I0orY		0.250-20 x 0 437, for side or bottom connection
	0015500		0 312 18 x 0 625 for back or bottom high pressure connection
23	M0138AM	1	Chart Plate
24	0020853	1	Time Set Pointer
25	B0107FK	1	Electrical Connector
26	0001302	2	Screw, pnh, 0 099-48 x 0 125
27	0020728	1	Nut Plate (for time set pointer)

Note: Chart Drives with other voltages, winds. and rotations are available. See PL 001-110.

**Additional Required Parts**

**Flush Mounting**

<u>Part No</u>	<u>Qty</u>	<u>Part Name</u>
0005653	9	Washer
0012354	12	Nut, 0 250-20
0020473	2	Screw, filh, 0.164-32 x 0 438
0022324	3	Bolt, French h, 0 250-20 x 1.500
0022326	3	Bolt, French h, 0.250-20 x 2.250
0024810	1	Door Assembly (see PL 001-217)
0028902	3	Nut, 0.164-32

**Portable Mounting**

<u>Part No</u>	<u>Qty</u>	<u>Part Name</u>
M0140AN	3	Screw, hexh, 0 250-20 x 0.875
MH0140AP	3	Nut, 0.250-20
Below	1	Portable Stand
0040300		For Pressure and Temperature (except rear extension helical)
M0140AL		All others

**Yoke Mounting**

<u>Part No</u>	<u>Qty</u>	<u>Part Name</u>
Below	1	Yoke (includes mounting screws and nuts)
0015927		Temperature and pressure instruments
0036356		Float and cable Instruments
A030059		Float and tape instruments

**Parts List**

**PL  
001-217**

January 1985

**12 INCH  
CIRCULAR CASE  
DOOR ASSEMBLIES**

The logo for Foxboro, featuring the word "FOXBORO" in a bold, italicized, sans-serif font. The letters are black with a white outline, and the word is set against a black rectangular background. A registered trademark symbol (®) is located to the upper right of the word.

© 1985 by The Foxboro Company

®Registered Trademark

Surface or Yoke Mounted

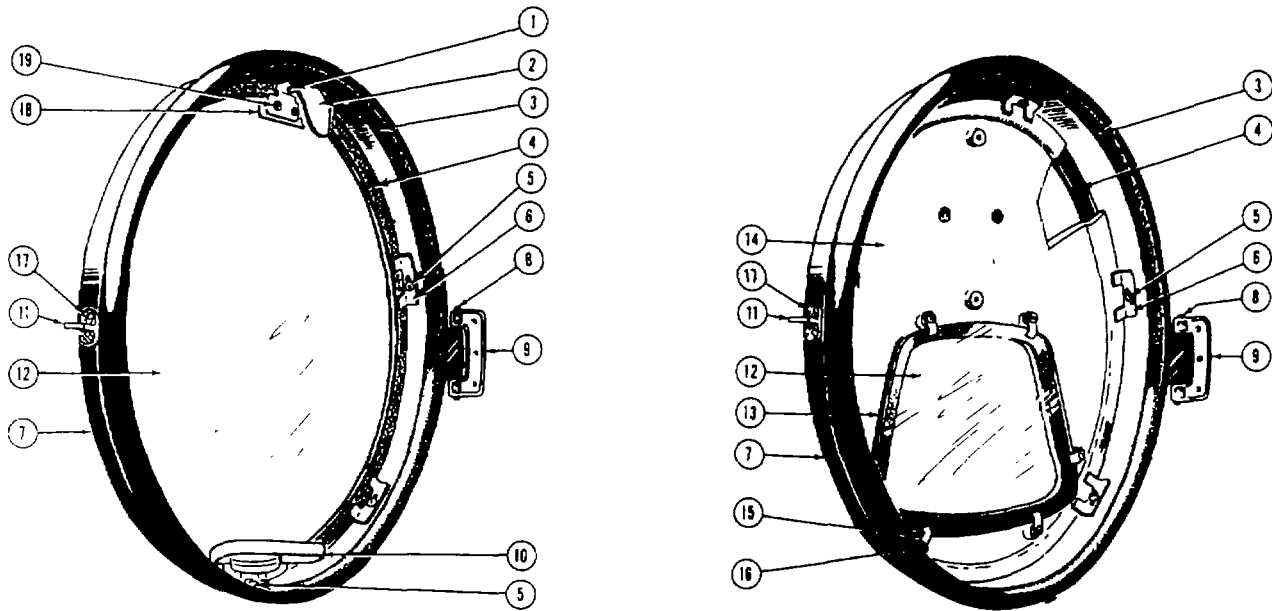

Figure 84375 Figure 84376

Assembly M0117HT - For Recorder or Concentric Indicator

Assembly M0117PA - For Recorder or Concentric Indicator with Shatterproof Glass

Assembly M0117NA - For Sector Indicator

Assembly M0117PW - For Instrument with Closed Front

ITEM	PART NAME	PART NO.	Quantity			
			M0117MT	MO117PA	M0117NA	M0117PW
	Door Assembly (items 1-7, 10-19)					
1	Screw, rdh, 0.125-40 x 0.156	X0100CB	2	2		2
2	Finger (see note 2, page 3)	M0145EK	1	1		1
3	Rubber Gasket R0125EBC	1		1	1	
3	Rubber Gasket 0037652		1			
4	Gasket Strip 0021272	1	1	1	1	
5	Screw, rdh, 0.125-40 x 0.125	X0116LZ	6	6	6	6
6	Clip M0117SR	6	6	6	6	
7	Ring M0117MW	1	1	1	1	
8	Pin, Threaded M0117MX	1	1	1	1	
9	Hinge M0117MY	1	1	1	1	
10	Card Holder (see note 2, page 3)	M014SCF	1	1		1
11	Hook M0117PS	1	1	1	1	
12	Glass (see note 3, page 3)	0001989	1		1	
12	Glass. Shatterproof	0022280		1		
12	Glass (see note 1, page 3)	M0117CL			1	
13	Gasket M0117FW			1		
14	Cover Plate (sector indicator)	M0117CK			1	
14	Cover Plate (closed front)	0038418				1
15	Clip 0013221		6			
16	Screw, rdh, 0 125-40 x 0.188	0013262			6	
17	Screw, rdh. 0 125-40 x 0.313	X0116CW	2	2	2	2
18	Nameplate, Foxboro	M0128FR	1	1	1	1
19	Speed Nut 0049406	2	2	2	2	
	Hasp (for instrument case)	M0138CY		(1 per Instrument case)		
	Screw, rdh, 0 190-32 x 0 375 (for, hasp)	0004120		(2 per Instrument case)		
	Door Gasket Cement (2 oz )	0048860				



**Flush-Mounted**

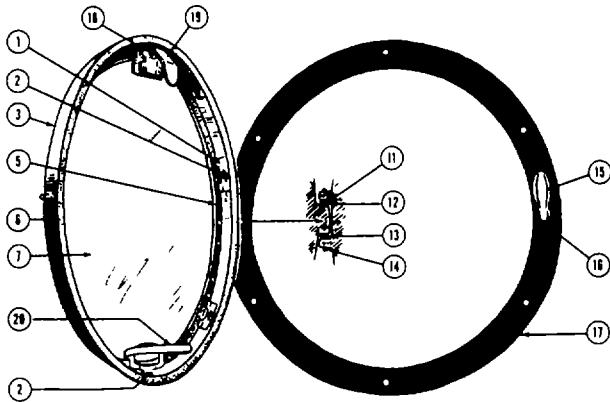

Figure B3415  
Assembly 0024810 - For Recorder or Concentric Indicator  
Assembly M01178R - For Sector Indicator

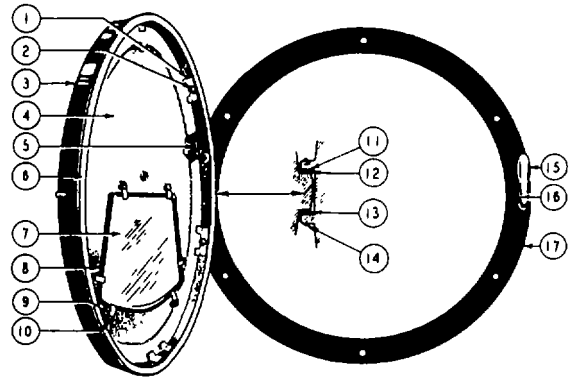

Figure 11258

ITEM	PART NAME	PART NO	QUANTITY	
			0024810	M0117BR
	Door and Flush Ring Assy			
1	Clip M0117SR	6	6	
2	Screw, rdh, 0.125-40 x 0.125	X0116LZ	6	6
3	Ring 0024811	1		
4	Cover Plate M0117CK		1	
5	Gasket Strip 0021272	1	1	
6	Rubber Gasket R0110AA	4 ft	4 ft	
7	Glass (see note 3)	0001989	1	
7	Glass (see note 1)	M0117CL		1
8	Gasket M0117FW		1	
9	Clip 0013221	6		
10	Screw, rdh. 0.125-40 x 0.188	0013262		6
11	Washer 0033544	1		
12	Shap Ring 0033543	1	1	
13	Washer 0024818	1		
14	Hinge Pin 0037874	1	1	
15	Hasp 0036255	1		
16	Shap Ring 0039605	1	1	
17	Flush Ring 0024813	1	1	
18	Screw, rdh, 0.125-40 x 0.156	X0100CB	2	
19	Finger (see note 2)	M0145EK	1	
20	Card Holder (see note 2)	M0145CF	1	
-	Foxboro Nameplate	MH0128FR	1	1
-	Speed Nut (for nameplate)	0049406	2	2
-	Door Gasket Cement (2 oz.)	0048860		

Notes.

1. Shatterproof glass, part M0117CZ, is available for sector indicators.
2. Concentric indicators have card holder, part 0021885, in place of part M0145CF. Finger, part M0145EK, is omitted.
3. Plexiglass disc, part A068591, is available as a substitute for glass, part 0001989, in recorders and concentric indicators.

---

**Notes**

MB 150 Printed in U.S.A.

0185

## GENERAL INSTRUCTIONS

Foxboro designs, manufactures, and tests its products to meet many national and International standards. However, for these products to operate within their normal specifications, you must properly install, use, and maintain these products. The following instructions must be adhered to and integrated with your safety program when installing, using, and maintaining Foxboro products.

- Read and save all instructions prior to installing, operating, and servicing the product.
- If you do not understand any of the instructions, contact your Foxboro representative for clarification.
- Follow all warnings, cautions, and instructions marked on and supplied with the product.
- Inform and educate your personnel in the proper installation, operation, and maintenance of the product.
- Install your equipment as specified in Foxboro site planning/Installation Instructions and per applicable local/national codes. Connect all products to the proper electrical and/or pressure sources.
- Handle, move, and install each product using the appropriate number of personnel and moving devices/equipment (dolly, forklift, crane, etc.) Failure to do so could cause serious personal injury.
- To ensure proper performance, use qualified personnel to install, operate, update, program, and maintain the product.
- When replacement parts are required, ensure that the qualified service technician uses replacement parts specified by Foxboro. Unauthorized substitutions may result in fire, electrical shock, other hazards, or improper equipment operation.
- Ensure that all equipment doors are closed and protective covers are in place, except when maintenance is being performed by qualified personnel, to prevent electrical shock and personal injury.

The logo for Foxboro, featuring the word "FOXBORO" in a bold, italicized, sans-serif font with a registered trademark symbol (®) to the upper right. The text is set against a dark, horizontal rectangular background.

## PRESSURE MOVEMENTS

SPIRALHELICAL DIAPHRAGM

BELLOWS

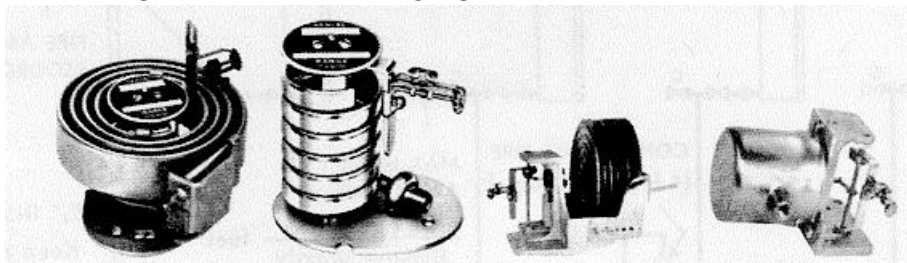

COMMON PRESSURE MEASURING ELEMENTS

### Principle of Operation

A pressure movement consists of a measuring element designed to expand or contract with changes in internal pressure. The resulting mechanical motion is transferred by a linkage to a pen or pointer. These measuring elements are operated by pressures either above or below atmospheric, therefore they can be used to measure vacuum as well as positive pressure. Also,

compound ranges of both pressure and vacuum can be measured.

The pressure at any point below the surface of a liquid is a measure of the height of liquid above that point. Therefore, pressure instruments can also be calibrated to read directly in terms of liquid level.

### Piping Details (see Page 2 for piping arrangements)

1. All piping to be 1/4-inch pipe or 3/8-inch tubing of material and thickness to suit the application.
2. When installing piping, external connections on the instrument can be identified by tracing each connection to its element and referring to the nameplate on the element.
3. With gas or steam applications, connections at the pipe or vessel are to be made on the top or side. With liquid applications, connections are to be made on the side only. Pitch all horizontal lines for drainage or venting.
4. If the fluid being measured has excessive pressure fluctuations or pulsations, a fluid damper should be installed. If the fluid is corrosive, viscous, or has solids in suspension, a pressure seal or purge should be used.
5. Pressure elements must never be subjected to pressures above their range unless they have overrange protection.

### Elevation Correction (liquid-filled systems only)

If the instrument is zeroed at the level of the vessel or line (as described on Page 2), no correction is required. If the instrument is checked against a test gauge *at the level of the instrument*, the elevation correction must be made.

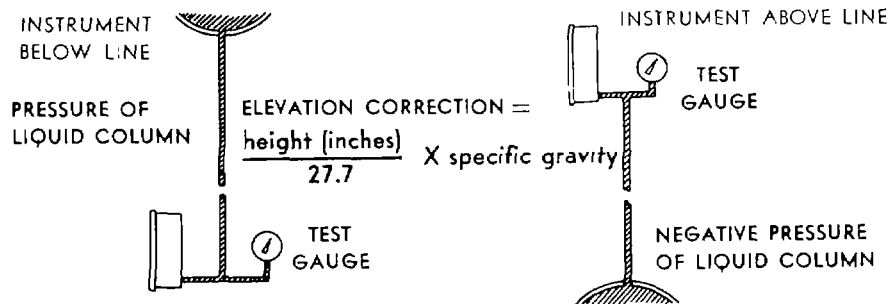

Instrument reads high; adjust pen downward with Zero adjustment.

Instrument reads low; adjust pen upward with Zero adjustment.



### Piping Arrangements

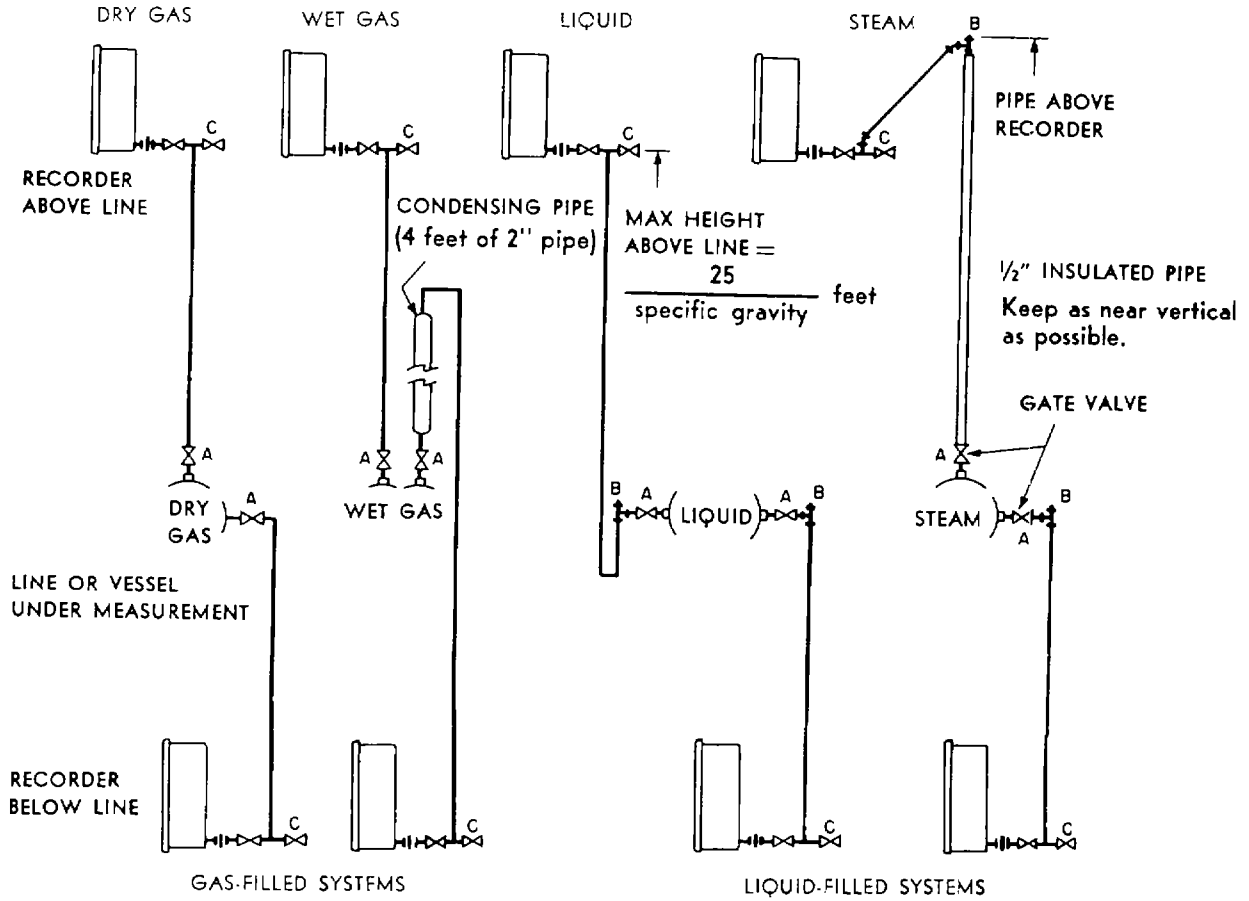

TO ZERO

TO FILL LINE (before zeroing)

Close valve A and open valve C Use pen zero adjustment to bring pen to zero Close C and open valve A

Valve C can be used for initial drainage in wet gas applications with recorder below line

Open valve A Open valve A and Open valve C until allow piping be- liquid flows free of tween B and record- bubbles Close valve er to fill with condensate

TO ZERO

After lines are filled (above) close valve A and remove plug B Use pen Zero adjustment to bring pen to zero Replace plug B and open valve A

### Zero Adjustment

ADJUSTMENT SCREWS



ROUND-CASE INSTRUMENTS

1 AND 2 PEN RECORDER 3 AND 4 PEN RECORDER

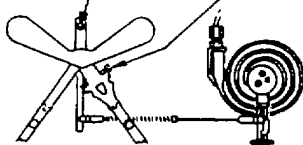

MODEL 40 INSTRUMENTS

A test gauge can be attached to valve C to check the calibration With liquid-filled systems, an elevation correction is necessary (see Page 1 )

**CALIBRATION AND REPLACEMENT OF  
PRESSURE ELEMENTS**

Instruments in Model 40, 40M, and 40P Cases

**CALIBRATION APPARATUS**

Upper Range Values of up to 30 kPa or 4 psi - water column

Upper Range Values of 200 kPa or 30 psi and up.

Upper Range Values of 30 through 200 kPa or 4 through 30 psi - mercury column

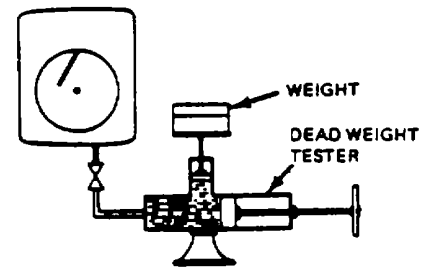
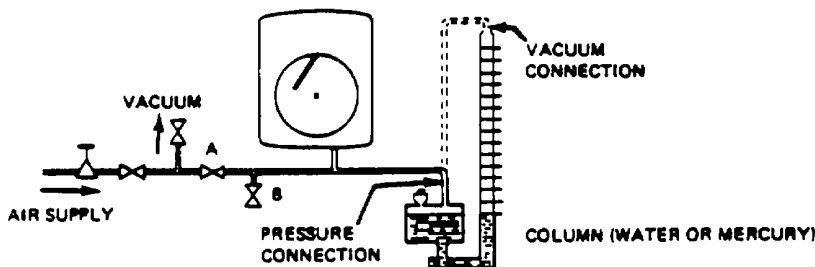

Lock in desired pressure or vacuum with valve A. Pressure can be reduced by bleeding valve B. An accurate test gauge may be used in place of column.

Increase pressure with crank until pressure supports an accurately-known weight. An accurate test gauge may be used with hydraulic pump in a similar setup.

**Squaring Up of Linkage for Complete Calibration**

If parts have been replaced, or for some other reason a complete recalibration is necessary, square up the linkage before the actual calibration. 1. Set pressure at middle of element range (see range on element name-plate).

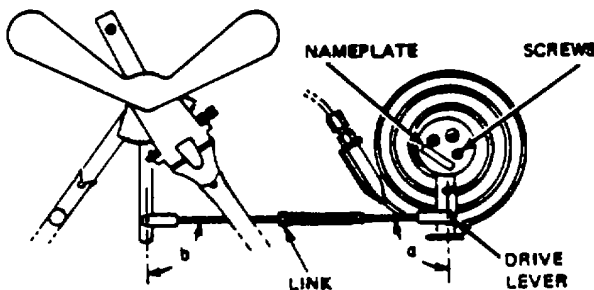

1. Set pressure a middle of element range (see range on element nameplate).
2. Obtain right angle (a) by loosening the two screws on top of element and slipping drive lever on its shaft
3. Obtain right angle (b) by adjusting length of link.



### Calibration Procedure

Before calibrating, make sure that the pen friction is not excessive, and that there is no excess friction or dead space elsewhere See Instruction MI 1-435.

1. Set pressure at minimum value (see range on element nameplate).
2. If pen does not read correctly, use zero adjustment to reposition pen.
3. Set pressure at maximum value. If pen does not read correctly, use multiplication adjustment to position pen about halfway toward the correct reading.
4. Repeat Steps 1, 2, and 3 until both readings of pen are correct.
5. Set pressure at mid-range. If pen is not at midscale, adjust length of link to move pen about five times the amount of error in direction of error. (Subsequent refinement in settings of adjustments will bring instrument into calibration.)
6. Repeat Steps 1 through 5 until all readings of pen are correct.

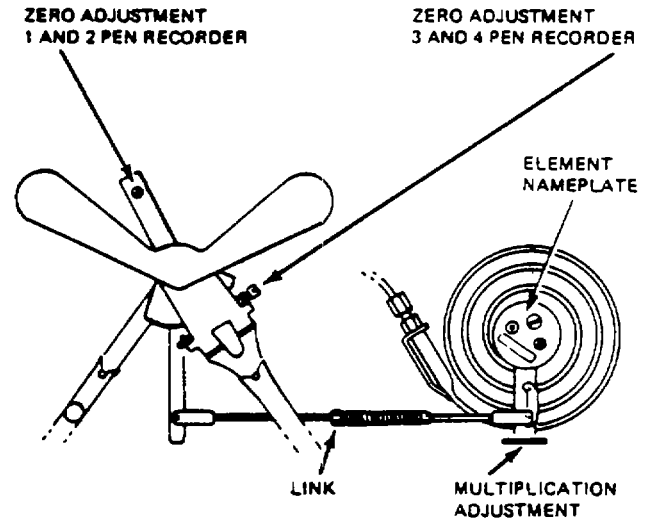

### TO REPLACE MEASURING ELEMENT

1. Disconnect link from pen movement. Note which hole link is in. (A precalibrated link and mounting plate are supplied with each replacement element).
2. Trace outline of mounting plate to indicate location for replacement. Remove the two mounting screws.
3. Unscrew tubing connection and remove assembly.
4. After replacing element assembly, check calibration.

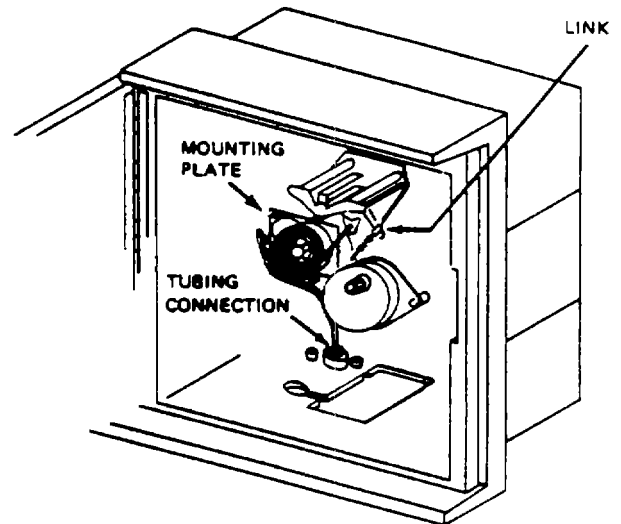

***Instruments and Systems for***

***Indicating, Recording, Controlling. . .***

Air Weight	Gas Analysis	Power, Electric	
Blending	Humidity	Pressure	
Buoyancy	Interface	Resistance, Electric	
Composition	Ion Selection	Specific Gravity	
Compression	Liquid Analysis	Speed	
Concentration, Solution		Liquid Level	Strain
Conductivity, Solution		Load	Stress
Consistency	Moisture Content	Temperature	
Current - ac	Motion	Tension	
Density	Motor Load	Thrust	
Dew Point	Operation, Schedule	Torque	
Displacement	Operation, Time	Vacuum	
Drag	Oxidation-Reduction Potential	Vapor Pressure	
Flow	pH Voltage		
Force	Position Weight		

The Foxboro Company sells and services more than 1,000 products used to measure, analyze, indicate, record, and control such process variables as flow, temperature, pressure, level, and composition. Products range from instruments that sense and transmit these variables to computer-based systems that control entire plants. Industries served are chemical, oil and gas, power, pulp and paper, food, metals, minerals, marine, and textile.

Manufactured in 9 countries, Foxboro products are identical in design and performance around the world, where they are sold and serviced in 160 major industrial areas. documentation, and training.

Corporate offices are located at:

Bristol Park  
Foxboro, Massachusetts, USA 02035



®Registered Trademark

Printed in U.S.A.



APPENDIX A

REFERENCES

**A-1. Scope.** This appendix contains all forms, pamphlets and technical manuals referenced in both the Air mobile and Semitrailer mounted Laboratories

**A-2. Forms.**

Recommended Changes to Publications ..... DA Form 2028  
 DA Form 2028-2  
 Quality Deficiency Report.....SF 368  
 Equipment Inspection and Maintenance Work Sheet..... DA Form 2404  
 Hand Receipts DA Form 2062

**A-3. Field Manuals.**

Petroleum Testing Facilities:

Laboratories and Kits ..... FM 10-72  
 Inspecting and Testing Petroleum Products..... FM 10-70  
 ASTM Test Method Supplement to..... FM 10-92C1/C2

**A-4. Technical Manuals.**

Atlas-Copco Compressor..... TM 10-4310-392-13&P  
 Alcor Jet Fuel Thermal Oxidation Tester Operating  
 and Maintenance Manual..... TM 10-6635-210-13&P  
 Bacharach Gas Alarm and Calibration Data.. ..... TM 10-6665-297-13&P  
 Brother Portable Typewriter..... TM 10-7430-218-13&P  
 Chemtrix Field Ph Meter..... TM 10-6630-237-13&P  
 Elkay Manufacturing 30 GPH Cooler ..... TM 10-4130-240-13&P  
 Emcee Micro-Separometer ..... TM 10-6640-222-13&P  
 Foxboro Pressure Recording Gauge ..... TM 10-6685-365-13&P  
 Gammon Aqua Glo Water Detector..... TM 10-6640-221-13&P  
 Gammon Mini Monitor Fuel Sampling Kit..... TM 10-6630-230-13&P  
 Jelrus Burn-Out Furnace ..... TM 10-6640-231-13&P  
 Koehler Cleveland Open Tester ..... TM 10-6630-236-13&P  
 Koehler Cloud and Pour Point Chamber..... TM 10-6630-238-13&P  
 Koehler Copper Strip Corrosion Bomb Bath ..... TM 10-6640-220-13&P  
 Koehler Distillation Apparatus ..... TM 10-6630-233-13&P  
 Koehler Dropping Point Apparatus ..... TM 10-6635-211-13&P  
 Koehler Electric Pensky-Martins Tester..... TM 10-6630-231-13&P  
 Koehler Foaming Characteristics Determination Apparatus ..... TM 10-6640-228-13&P  
 Koehler Kinematic Viscosity Bath..... TM 10-6630-239-13&P  
 Koehler Tag Closed Cup Flash Tester ..... TM 10-6630-235-13&P  
 Lab-Line Explosion Proof Refrigerator..... TM 10-6640-219-13&P  
 Lily Freezer TM 10-6640-234-13&P  
 Millipore OM 39 Filter Holder ..... TM 10-6640-225-13&P  
 Millipore Vacuum Pump..... TM 10-6640-217-13&P  
 Ohaus Harvard Trip Balance ..... TM 10-6670-278-13&P  
 Precision Gas-Oil Distillation Test Equipment ..... TM 10-6630-219-13&P  
 Precision General Purpose Water Bath..... TM 10-6640-229-13&P

Precision High Temperature Bronze Block Gum Bath .....	TM 10-6630-234-13&P
Precision General Purpose Ovens .....	TM 10-6640-218-13&P
Precision Heater Instruction Manual and Parts List.....	TM 10-6640-223-13&P
Precision Oxidation Stability Bath.....	TM 10-6640-232-13&P
Precision Pensky-Martens Flash Testers .....	TM 10-6630-231-13&P
Precision Reid Vapor Pressure Bath.....	TM 10-6640-226-13&P
Precision Slo-Speed Stirrer.....	TM 10-6640-224-13&P
Precision Universal Centrifuge.....	TM 10-6640-230-13&P
Precision Universal Penetrometer.....	TM 10-6640-228-13&P
Sargent-Welch Vacuum Pump.....	TM 10-4310-391-13&P
Sartorius Analytical Balance .....	TM 10-6670-277-13&P
Scotsman Cuber TM 10-6640-227-13&P	
Soltec VOM-Multimeter.....	TM 10-6625-3127-13&P
Teel Self-Priming Centrifugal Pump.....	TM 10-6640-217-13&P
Teel Submersible Pump.....	TM 10-4320-320-13&P
Texas Instrument TI-503011 Calculator.....	TM 10-7420-210-13&P

**A-5. Pamphlets.**

The Army Maintenance Management System (TAMMS) .....	DA Pam 738-750
--	----------------

**A-6. Miscellaneous Publications.**

The Army Integrated Publishing and Printing Program .....	AR 25-30
Laboratory, Airmobile, Aviation Fuel .....	MIL-L-52733A(ME)
Apparatus, Instruments, Chemicals, Furniture, and Supplies for Industrial, Clinical, College and Government Laboratories .....	Fisher Scientific Laboratories Catalog
Petroleum-Petrochemical Testing Equipment.....	Precision Scientific Catalog

## APPENDIX B

## MAINTENANCE ALLOCATION CHART

## Section I. INTRODUCTION

**B-1. General.**

a. This section provides a general explanation of all maintenance and repair functions authorized at various maintenance categories.

b. The Maintenance Allocation Chart (MAC) In Section II designates overall authority and responsibility for the performance of maintenance functions on the identified end item or component. The application of the maintenance functions to the end item or component will be consistent with the capacities and capabilities of the designated maintenance categories

c. Section II lists the tools and test equipment (both special tools and common tool sets) required for each maintenance function as referenced from Section II.

d. Section IV contains supplemental Instructions and explanatory notes for a particular maintenance function.

**B-2. Maintenance Functions.** Maintenance functions will be limited to and defined as follows

a. Inspect. To determine the serviceability of an item by comparing its physical, mechanical, and/or electrical characteristics with established standards through examination (e g., by sight, sound, or feel).

b. Test. To verify serviceability by measuring the mechanical, pneumatic, hydraulic, or electrical characteristics of an item and comparing those characteristics with prescribed standards.

c. Service. Operations required periodically to keep an item in proper operating condition, i e., to clean (Includes decontaminate, when required), to preserve, to drain, to paint, or to replenish fuel, lubricants, chemical fluids, or gases.

d. Adjust. To maintain or regulate, within prescribed limits, by bringing into proper or exact position, or by setting the operating characteristics to specified parameters.

e. Align. To adjust specified variable elements of an item to bring about optimum or desired performance.

f. Calibrate To determine and cause corrections to be made or to be adjusted on instruments or test, measuring, and diagnostic equipments used in precision measurement Consists of comparisons of two instruments, one of which is a certified standard of knob accuracy, to detect and adjust any discrepancy in the accuracy of the instrument being compared

g. Remove/Install. To remove and install the same item when required to perform service or other maintenance functions. Install may be the act of emplacing, seating, or fixing into position a spare, repair part, or module (component or assembly) in a manner to allow the proper functioning of an equipment or system.

h. Replace To remove an unserviceable item and install a serviceable counterpart in its place "Replace" is authorized by the MAC and is shown as the third position code of the SMR code.

i. Repair. The application of maintenance services, including fault location/troubleshooting,<sup>2</sup> removal/installation, and disassembly/assembly procedures<sup>3</sup> and maintenance actions<sup>4</sup> to identify troubles and restore serviceability to an item by correcting specific damage, fault, malfunction, or failure in a part, subassembly, module (component or assembly), end item, or system.

j. Overhaul. That maintenance effort (service/action) prescribed to restore an item to a completely serviceable/operational condition as required by maintenance standards in appropriate technical publications (i.e., DMWR) Overhaul is normally the highest degree of maintenance performed by the Army. Overhaul does not normally return an item to like-new condition.

k. Rebuild. Consists of those services/actions necessary for the restoration of unserviceable equipment to a like-new condition in accordance with original manufacturing standards Rebuild is the highest degree of materiel maintenance applied to Army equipment The rebuild operation Includes the act of returning to zero those age measurements (hours/miles, etc.) considered In classifying Army equipment/components.

**B-3. Explanation Of Columns In The MAC, Section II.**

a. Column 1. Group Number. Column 1 lists functional group code numbers, the purpose of which is to identify maintenance significant components, assemblies, subassemblies, and modules with the next higher assembly End item group number shall be "00."

b. Column 2. Component/Assembly. Column 2 contains the names of components, assemblies, subassemblies, and modules for which maintenance is authorized.

c. Column 3 Maintenance Function Column 3 lists the functions to be performed on the item listed in column 2. (For a detailed explanation of these functions, see paragraph B-2.)

d. Column 4. Maintenance Category. Column 4 specifies, by the listing of a work time figure in the appropriate subcolumn(s), the category of maintenance authorized to perform the function listed In column 3. This figure represents the active time required to perform that maintenance function at the indicated category of maintenance. If the number or complexity of the tasks within the listed maintenance function vary at different maintenance categories, appropriate work time figures will be shown for each category. The work time figure represents the average time required to restore an item (assembly, subassembly, component, module, end item, or system) to a serviceable condition under typical field operating conditions This time includes preparation time (including any necessary disassembly/ assembly time), troubleshooting/fault location time, and quality assurance/quality control time in addition to the time required to perform the specific tasks Identified for the maintenance functions authorized In the maintenance allocation chart. The symbol designations for the various maintenance categories are as follows'

<sup>1</sup> Services - inspect, test, service, adjust, align, calibrate, and/or replace

<sup>2</sup> Fault locate/troubleshoot- the process of investigating and detecting the cause of equipment malfunctioning; the act of Isolating a fault within a system or unit under test (UUT)

<sup>3</sup> Disassemble/assemble - encompasses the step-by-step taking apart (or breakdown) of a spare/functional group coded item to the level of least componency identified as maintenance significant (I e, assigned an SMR code) for the category of maintenance under consideration

<sup>4</sup> Actions - welding, grinding, riveting, straightening, facing, remachining, and/or resurfacing

- C ..... Operator/Crew
- O ..... Unit Maintenance
- F ..... Direct Support Maintenance
- H ..... General Support Maintenance
- D ..... Depot Maintenance

e. Column 5. Tools and Equipment Column 5 specifies, by code, those common tool sets (not individual tools) and special tools, TMDE, and support equipment required to perform the designated function

f. Column 6. Remarks. This column shall, when applicable, contain a letter code, in alphabetic order, which shall be keyed to the remarks contained in section IV.

**B-4. Explanation Of Columns In Tool And Test Equipment Requirements, Section III.**

a. Column 1. Reference Code. The tool and test equipment reference code correlates with a code used in the MAC, section II, column 5.

b. Column 2. Maintenance Category The lowest category of maintenance authorized to use the tool or test equipment.

c. Column 3. Nomenclature Name or identification of the tool or test equipment

d. Column 4. National Stock Number. The National stock number of the tool or test equipment

e. Column 5. Tool Number The manufacturer's part number.

**B-5. Explanation Of Columns In Remarks, Section IV.**

a. Column 1. Reference Code. The code recorded In column 6, Section II.

b. Column 2. Remarks. This column lists information pertinent to the maintenance function being performed as indicated in the MAC, section II

**Section II. MAINTENANCE ALLOCATION CHART**

(1) GROUP NUMBER	(2) MAINTENANCE COMPONENT	(3) MAINTENANCE UNIT	(4) ASSEMBLY	(5) MAINTENANCE LEVEL	(6) DS FUNCTION	DEPOT TOOLS AND					EQUIPMENT	REMARKS
						GS						
						C	O	F	H	D		
01			GAUGE, PRESSURE RECORDING		INSPECT REPLACE REPAIR CALIBRATE	0 1 0 5	1 0 5					1

**Section III. TOOL AND TEST EQUIPMENT REQUIREMENTS  
FOR  
MAINTENANCE ALLOCATION CHART**

(1)(2) TOOL OR TEST EQUIPMENT REF CODE	(3) MAINTENANCE CATEGORY	(4) (5) NOMENCLATURE	NSN	TOOL NUMBER
1	F	TOOL KIT, GENERAL AUTOMOTIVE	5180-00--177-7033	(50980) SC 5180-90- CL-N26

**Section IV. REMARKS**

**NOT APPLICABLE**

**APPENDIX C**

**COMPONENTS OF END ITEM AND BASIC ISSUE ITEMS LISTS**

**NOT APPLICABLE**

**C-1/(C-2 Blank)**

APPENDIX D

ADDITIONAL AUTHORIZATION LIST

NOT APPLICABLE

D-1/(D-2 Blank)



APPENDIX E

EXPENDABLE/DURABLE SUPPLIES AND MATERIALS LIST

Section I. INTRODUCTION

**E-1. Scope.** This listing is for informational purposes only and is not authority to requisition the listed items. These items are authorized to you by CTA 50-970, Expendable/Durable Items (except medical, class V, repair parts, and heraldic items)

**E-2. Explanation of Columns.**

a. Column (1) - Item Number This number is assigned to the entry in the listing and is referenced in the narrative instructions to identify the material (e.g., Use cleaning compound, item 5, appendix C)

b. Column (2) - Level This column identifies the lowest level of maintenance that requires the listed item

- C - Operator/Crew
- O - Unit Maintenance
- F - Direct Support Maintenance
- H - General Support Maintenance

c. Column (3) - National Stock Number. This is the National stock number assigned to the item, use it to request or requisition the item

d. Column (4) - Description. Indicates the Federal Item name, and, if required, a description to identify the item. The last line for each item indicates the Commercial and Government Entity Code (CAGEC) in parentheses followed by the part number

e. Column (5) - Unit of Measure (U/M) Indicates the measure used in performing the actual maintenance function. This measure is expressed by a two-character alphabetical abbreviation (e.g., EA, IN, PR). If the unit of measure differs from the unit of issue, requisition the lowest unit of issue that will satisfy your requirements

Section II. EXPENDABLE/DURABLE SUPPLIES AND MATERIALS LIST

(1)(2) ITEM NUMBER	(3) NATIONAL STOCK LEVEL	(4)(5) DESCRIPTION NUMBER	U/M
	C	INK (15747) FOXBORO TYPE 1800 INK (COLOR)	OZ
	C	CHARTS (15747) 898413	

E-1/(E-2 Blank)